

# Instructions for Field Testing of Ground Fault Systems Utilizing Eaton Magnum DS<sup>®</sup> Circuit Breakers

The National Electrical Code makes the following statement regarding ground fault conformance testing:

### NEC 230-95c

“The ground fault protection system shall be performance tested when first installed. The test shall be conducted in accordance with approved instructions which shall be provided with the equipment. A written record of this test shall be made and shall be available to the authority having jurisdiction.”

This document is intended to provide instructions for conformance testing of ground fault systems utilizing type Magnum DS circuit breakers. Although the most common system variations are specifically illustrated, they are also used to form the basis for more complex systems. These instructions may be applied, accordingly, on these systems as well. Refer to order-specific drawings to determine the actual ground fault system supplied.



**DANGER**

**DO NOT ATTEMPT TO TEST THIS EQUIPMENT WHILE IT IS ENERGIZED. DEATH OR SEVERE PERSONAL INJURY COULD RESULT. TURN OFF ALL POWER SUPPLYING THIS EQUIPMENT AND CHECK FOR VOLTAGE BEFORE TESTING.**

Overall system selectivity and performance of integral ground fault protection equipment can be field tested only by using the high current primary injection method. When testing with this method, the following rules must be followed:

1. Tests are to be conducted by qualified personnel only.
2. The incoming line or source transformer must be **disconnected** from the switchgear.
3. Loads must be disconnected from the switchgear when testing feeder breaker ground fault. If only the mains or ties are to be tested, all feeder breakers must be open.
4. A single phase high current power supply will be required (approx. 1200A at approx. 2.5V). Flexible jumper cables, equal to the current that will be applied, will also be required.

### GROUND FAULT PICK-UP VALUES FOR MAGNUM DS BREAKERS.

GROUND FAULT PICKUP SETTINGS IN AMPERES <sup>①</sup>								
	0.25 <sup>②</sup>	0.3 <sup>②</sup>	0.35 <sup>②</sup>	0.4 <sup>②</sup>	0.5 <sup>②</sup>	0.6	0.75	1.0
200	50	60	70	80	100	120	150	200
250	63	75	88	100	125	150	188	250
300	75	90	105	120	150	180	225	300
400	100	120	140	160	200	240	300	400
600	150	180	210	240	300	360	450	600
800	200	240	280	320	400	480	600	800
1000	250	300	350	400	500	600	750	1000
1200	300	360	420	480	600	720	900	1200
1600	400	480	560	640	800	960	1200	1200
2000	500	600	700	800	1000	1200	1200	1200
2500	625	750	875	1000	1200	1200	1200	1200
3000	750	900	1050	1200	1200	1200	1200	1200
3200	800	960	1120	1200	1200	1200	1200	1200
4000	1000	1200	1200	1200	1200	1200	1200	1200
5000	1200	1200	1200	1200	1200	1200	1200	1200

① TOLERANCES ON PICKUP LEVELS ARE ±10% OF VALUES SHOWN.

② FOR TESTING PURPOSES ONLY: WHEN USING AN EXTERNAL GROUND SINGLE PHASE CURRENT SOURCE TO TEST LOW LEVEL GROUND FAULT CURRENT SETTINGS, IT IS ADVISABLE TO USE THE TEST KIT AND ASSOC. ADAPTER. WHEN THE SINGLE PHASE CURRENT IS LOW, IT MAY APPEAR AS IF THE TRIP UNIT DOES NOT RESPOND UNTIL THE CURRENT IS WELL ABOVE THE SET VALUE, LEADING THE TESTER TO BELIEVE THERE IS AN ERROR IN THE TRIP UNIT WHEN THERE IS NONE. THE REASON THIS OCCURS IS THAT THE SINGLE PHASE TEST CURRENT IS NOT A GOOD SIMULATION OF THE NORMAL THREE PHASE CIRCUIT. IF THREE PHASE HAD BEEN FLOWING, THE TRIP UNIT WOULD HAVE BEEN POWERED SUFFICIENTLY. USE THE TEST KIT AND ASSOC. ADAPTER FOR CORRECT TRIP UNIT PERFORMANCE WHEN SINGLE PHASE TESTS ARE MADE.

5. For RMS 520 Digitrip, a test kit and assoc. adapter will be required for each breaker undergoing simultaneous testing. For all other Digitrip types, either an auxiliary power supply module (Cat. No: PRTAAPM) will be required, or the power/relay module must be energized through its breaker secondary terminals. (See Table "A" Footnote 2).
6. On 4-wire systems, check to ensure that there are no additional grounds on the feeder breaker neutral conductors.

### OPTIONAL ZONE SELECTIVE INTERLOCKING GROUND FAULT OPERATION

Under a ground fault condition, the downstream breaker will send a restraining signal to the upstream breaker. This signal tells the upstream breaker to begin timing (assuming the fault current is above their pickup settings).

The downstream breaker should then clear the fault. If the downstream breaker fails to trip, the upstream breaker will then time out and clear the fault condition.

If the fault condition is located between the upstream breaker and the downstream breaker, the downstream breaker will not sense the fault and no restraining signal will be sent. The upstream breaker will then trip at its minimum time band, regardless of the time setting.

The pickup and time delay settings on the main, tie, and feeder breakers must be selectively coordinated.

**Note: If individual breaker testing is performed with the breaker withdrawn from the test or connected positions, terminals B8 & B9 must be jumpered to obtain time delay by use of secondary defeat adapter 8779C02G05.**

#### DIGITRIP RMS FIELD TESTING OF OPTIONAL ZONE INTERLOCKING

The following is a general procedure to check the zone interlocking functions and wiring. Primary injection is not required for this test. Drawout breakers must be in the test or connected position. The breakers must not be energized except control power. For RMS 520, use a Test Kit for each trip unit to obtain control power. See Test Kit instructions.

For all other Digitrip RMS trip units, use an Auxiliary Power Module to power the trip units. The APM is powered from a 120VAC receptacle, the power cord plugs into a jack on the front of the trip unit. Auxiliary power module is required. The Digitrip RMS green status "LED" should be flashing.

#### Preliminary:<sup>①</sup>

For ease of testing, make the following settings. They should be turned back to the desired settings after testing is complete. Make these settings on both the downstream and upstream trip units:

① Test Amps	=	GFT
Ground Fault Pick-up	=	0.35
Ground Fault Time	=	0.5

#### TEST 1 – Self-Interlocked Feeders

Verify each feeder breaker trips with time delay when self-interlocked.

Push test pushbutton and release to start the test. The breaker should trip with time delay. Push reset on Digitrip and reclose breaker. Do this for each feeder breaker and verify delayed tripping occurs.

**NOTE: Self-interlocking is defined as the feeder breaker having a jumper installed on secondary contacts B8 and B9. When this jumper is installed, it allows the ground fault time delay to operate at the trip unit setting. Without this jumper, the ground fault time delay will always revert to the minimum time setting (0.1) regardless of the trip unit setting. The self-interlocked jumpers should only be on the furthest downstream breakers in the zone interlock scheme.**

#### TEST 2 – No Delay Trip On Upstream Breakers (Normally mains and ties)

Verify that each upstream breaker will trip with no time delay (minimum setting 0.1), when not receiving a restraint signal from a downstream breaker.

Push test pushbutton and release to start the test. The breaker should trip without any time delay (minimum setting 0.1). Push reset on Digitrip and reclose breaker, repeat test for each upstream breaker.

#### TEST 3 – Delayed Trip

Verify that restraint signal sent by a downstream breaker to an upstream breaker does cause a time delay trip.

For Digitrip RMS 520, use the Test Kits to initiate simultaneous ground faults for both an up- and downstream breaker. The upstream breaker should trip with a 0.5 sec delay. For all other Digitrip trip units, choose a feeder adjacent to the main or tie that is to be tested. Push test pushbuttons on both breakers and release them simultaneously. The upstream breaker should trip with a 0.5 sec delay.

<sup>①</sup> Procedure is written for trip units which include an integral test feature. For trip units that do not have an integral test panel, use a Digitrip Test Kit for each breaker to initiate a ground fault trip. Follow Test Kit instructions to initiate a trip.

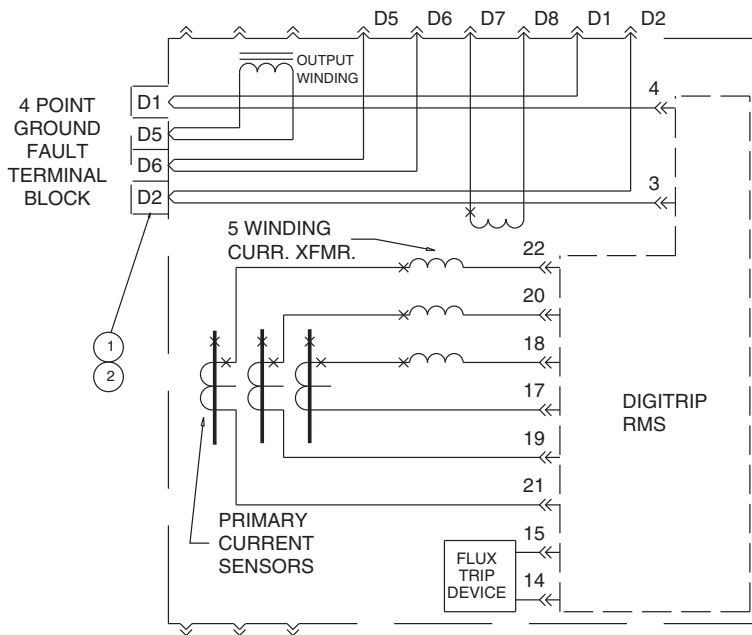

- ① CONNECT D5 TO D1 AND D6 TO D2 ON 4 POINT GF TERMINAL BLOCK FOR RESIDUAL SENSING.
- ② CONNECT D5 TO D6 ON 4 POINT GF TERMINAL BLOCK FOR SOURCE GROUND AND ZERO SEQUENCE SENSING.

**FIG. 1 CONNECTION DIAGRAM FOR MAGNUM DS RESIDUAL GROUND FAULT**

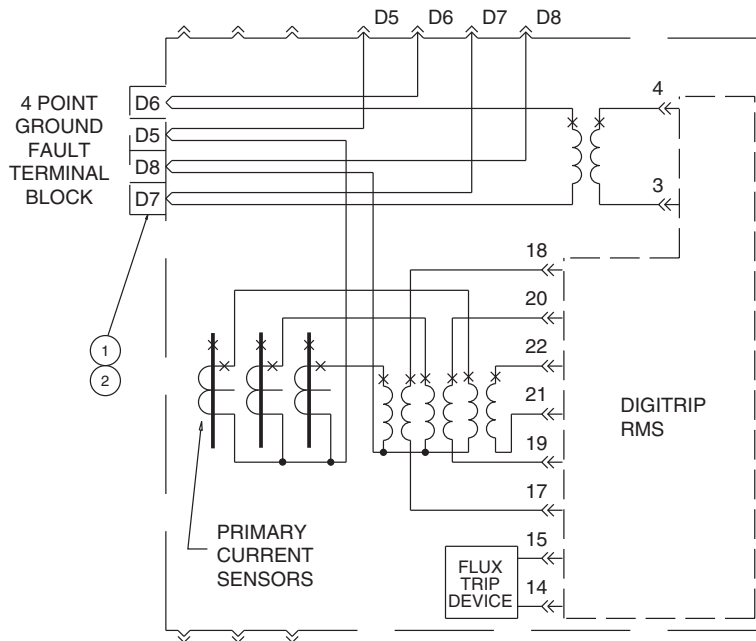

- ① CONNECT D5 TO D6 AND D7 TO D8 ON 4 POINT GF TERMINAL BLOCK FOR RESIDUAL SENSING.
- ② CONNECT D5 TO D8 ON 4 POINT GF TERMINAL BLOCK FOR SOURCE GROUND AND ZERO SEQUENCE SENSING.

**FIG. 2 CONNECTION DIAGRAM FOR MAGNUM DS SOURCE GROUND FAULT**

# TEST PROCEDURE FOR: 3 WIRE FEEDER BREAKER WITH RESIDUAL GROUND FAULT



**DANGER**

DO NOT ATTEMPT TO TEST THIS EQUIPMENT WHILE IT IS ENERGIZED. DEATH OR SEVERE PERSONAL INJURY COULD RESULT. TURN OFF ALL POWER SUPPLYING THIS EQUIPMENT AND CHECK FOR VOLTAGE BEFORE TESTING.

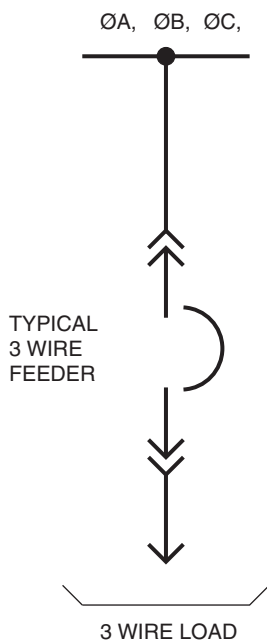

FIG. 3  
SINGLE LINE DIAGRAM  
OF FEEDER

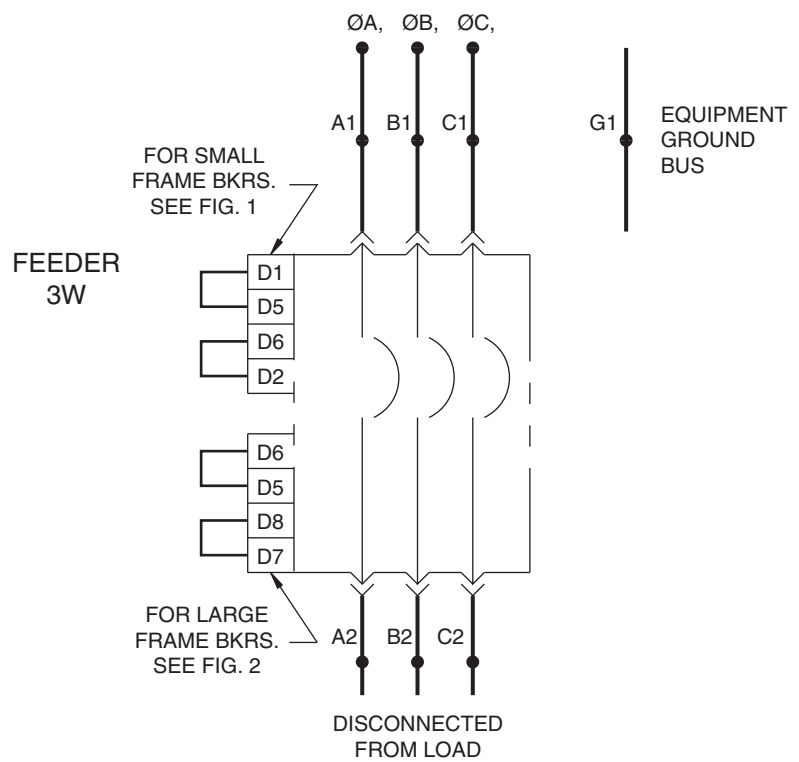

FIG. 4  
THREE LINE DIAGRAM  
INDICATING TEST POINTS

BREAKER STATUS FEEDER	APPLY 1Ø POWER TO	INSTALL JUMPER FROM	RESULTS	REMARKS
CLOSED	A1 & G1	A2 & G1	FEEDER TIMES OUT AND TRIPS	

REPEAT THE ABOVE TEST FOR “B” PHASE & “C” PHASE.

**NOTE:** If the above test does not pass, utilize Integral Test Panel® on Digitrip Unit to verify correct trip unit operation. If trip unit tests properly, check to see if incoming lines and loads are disconnected and that test power supply and jumper connections are correct.

®For Digitrip trip units without an integral test panel, use a Digitrip Test Kit for trip unit testing.

# TEST PROCEDURE FOR: 4 WIRE FEEDER BREAKER WITH RESIDUAL GROUND FAULT



**DANGER**

DO NOT ATTEMPT TO TEST THIS EQUIPMENT WHILE IT IS ENERGIZED. DEATH OR SEVERE PERSONAL INJURY COULD RESULT. TURN OFF ALL POWER SUPPLYING THIS EQUIPMENT AND CHECK FOR VOLTAGE BEFORE TESTING.

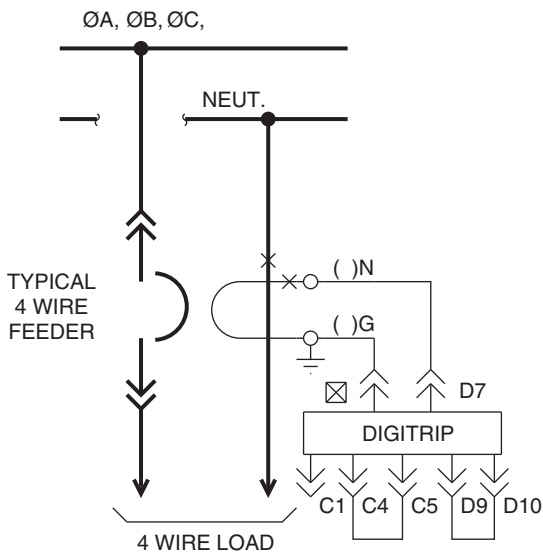

FIG. 5  
SINGLE LINE DIAGRAM  
OF FEEDER

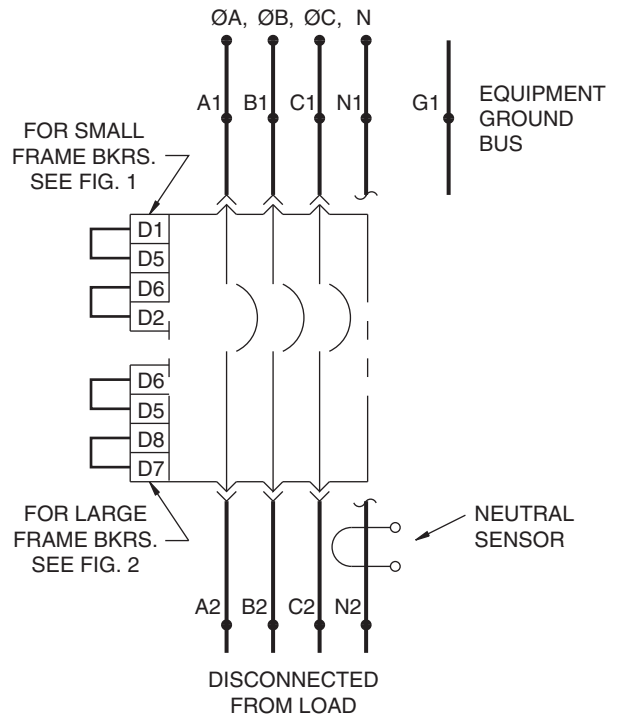

FIG. 6  
THREE LINE DIAGRAM  
INDICATING TEST POINTS

BREAKER STATUS FEEDER	APPLY 1Ø POWER TO	INSTALL JUMPER FROM	RESULTS	REMARKS
CLOSED	A1 & N1	A2 & N2	NO TRIP	POLARITY CHECK FOR NEUTRAL SENSOR
CLOSED	A1 & G1	A2 & G1	FEEDER TIMES OUT AND TRIPS	

REPEAT THE ABOVE TEST FOR "B" PHASE & "C" PHASE, EXCEPT NEUTRAL SENSOR POLARITY CHECK IS ONLY REQUIRED. ON ONE PHASE.

**NOTE:** If any of the above tests do not pass, utilize <sup>®</sup>Integral Test Panel on Digitrip Unit to verify correct trip unit operation. If trip unit tests properly, check to see if incoming lines and loads are disconnected and that test power supply and jumper connections are correct.

If "No Trip" test fails, reverse secondary connections at neutral sensor and repeat test. If test still fails, check that connections on breaker are per figure 1.

<sup>®</sup>For Digitrip trip units without an integral test panel, use a Digitrip Test Kit for trip unit testing.

# TEST PROCEDURE FOR: SINGLE ENDED, 3 WIRE SYSTEM<sup>2</sup>



**DANGER**

DO NOT ATTEMPT TO TEST THIS EQUIPMENT WHILE IT IS ENERGIZED. DEATH OR SEVERE PERSONAL INJURY COULD RESULT. TURN OFF ALL POWER SUPPLYING THIS EQUIPMENT AND CHECK FOR VOLTAGE BEFORE TESTING.

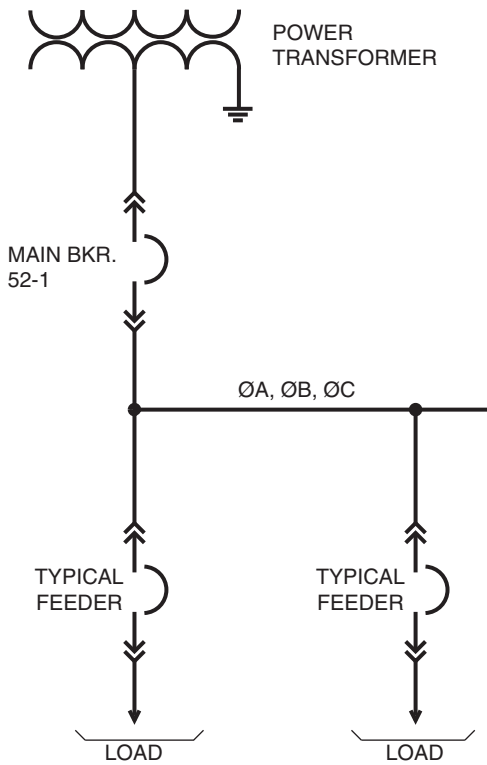

FIG. 7  
SINGLE LINE DIAGRAM  
OF SWITCHGEAR

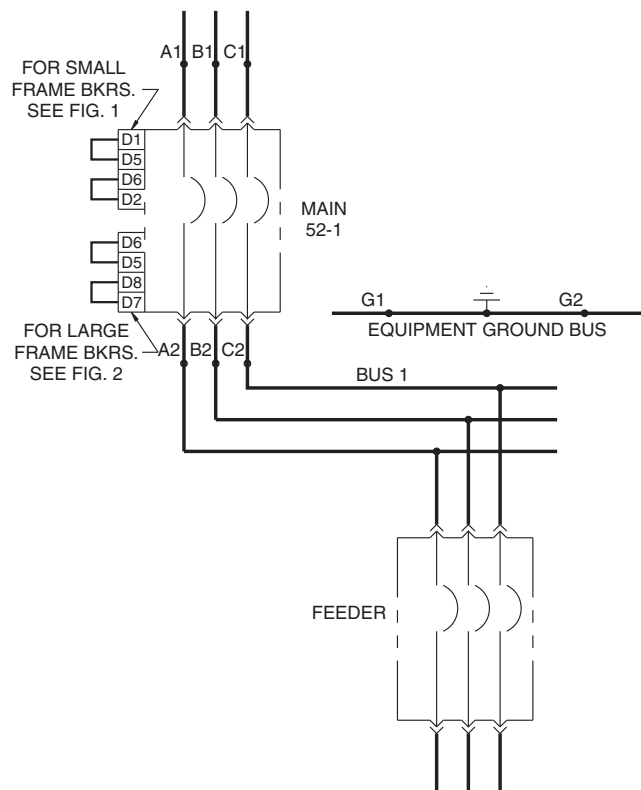

FIG. 8  
THREE LINE DIAGRAM  
INDICATING TEST POINTS

BREAKER STATUS		APPLY 1Ø	INSTALL	RESULTS	REMARKS
52-1	FEEDERS	POWER TO	JUMPER FROM		
CLOSED	OPEN	A1 & G1	A2 & G2	MAIN 52-1 TIMES OUT AND TRIPS	
FOR FEEDER BREAKER GROUND FAULT TEST REFER TO PAGE 4					

REPEAT THE ABOVE TEST FOR "B" PHASE & "C" PHASE

**NOTE:** If the above test does not pass, utilize Integral Test Panel<sup>®</sup> on Digitrip Unit to verify correct trip unit operation. If trip unit tests properly, check to see if incoming lines and loads are disconnected and that test power supply and jumper connections are correct.

<sup>1</sup>For Digitrip trip units without an integral test panel, use a Digitrip Test Kit for trip unit testing.

<sup>2</sup>Zone interlocking not wired

# TEST PROCEDURE FOR: SINGLE ENDED, 4 WIRE RESIDUAL SYSTEM<sup>2</sup>



**DANGER**

DO NOT ATTEMPT TO TEST THIS EQUIPMENT WHILE IT IS ENERGIZED. DEATH OR SEVERE PERSONAL INJURY COULD RESULT. TURN OFF ALL POWER SUPPLYING THIS EQUIPMENT AND CHECK FOR VOLTAGE BEFORE TESTING.

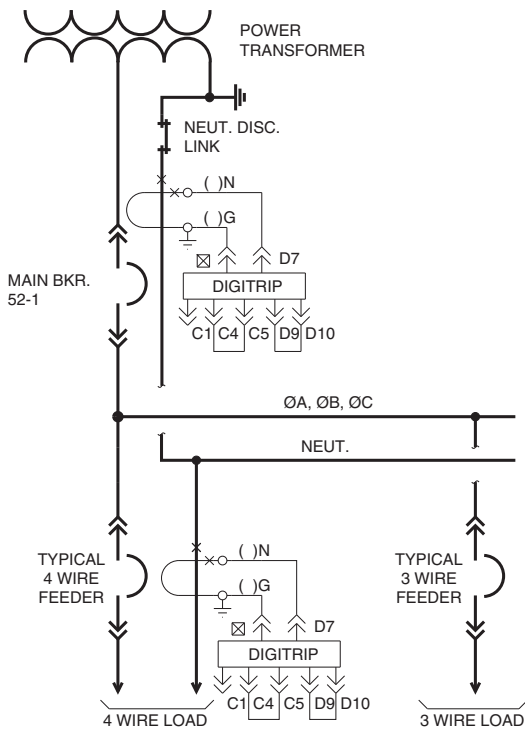

**FIG. 9  
SINGLE LINE DIAGRAM  
OF SWITCHGEAR**

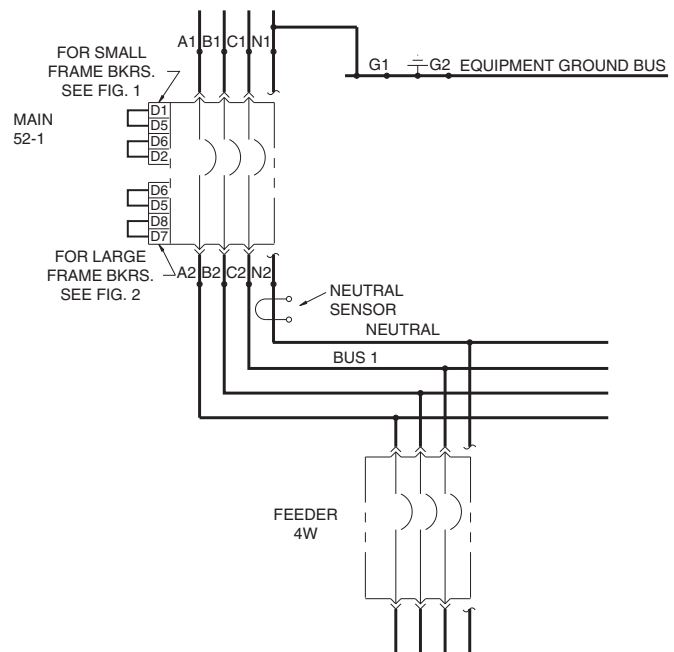

**FIG. 10  
THREE LINE DIAGRAM  
INDICATING TEST POINTS**

BREAKER STATUS		APPLY 1Ø	INSTALL	RESULTS	REMARKS
52-1	FEEDERS	POWER TO	JUMPER FROM		
CLOSED	OPEN	A1 & N1	A2 & N2	NO TRIP	POLARITY CHECK FOR NEUTRAL SENSOR
CLOSED	OPEN	A1 & G1	A2 & G2	MAIN 52-1 TIMES OUT AND TRIPS	
FOR FEEDER BREAKER GROUND FAULT TEST REFER TO PAGES 4 & 5					

REPEAT ALL OF THE ABOVE TESTS FOR "B" PHASE & "C" PHASE, EXCEPT NEUTRAL SENSOR POLARITY CHECK IS ONLY REQUIRED ON ONE PHASE.

**NOTE:** If any of the above tests do not pass, utilize Integral Test Panel<sup>®</sup> on Digitrip Unit to verify correct trip unit operation. If trip unit tests properly, check to see if incoming lines and loads are disconnected and that test power supply and jumper connections are correct.

If "No Trip" test fails, reverse secondary connections at neutral sensor and repeat test. If test still fails, check to verify that connections on breaker are per figure 1.

<sup>1</sup>For Digitrip trip units without an integral test panel, use a Digitrip Test Kit for trip unit testing.

<sup>2</sup>Zone interlocking not wired

# TEST PROCEDURE FOR: DOUBLE ENDED, 4 WIRE SYSTEM,<sup>2</sup> SINGLE POINT GROUNDING “T” CONNECTION MAGNUM DS

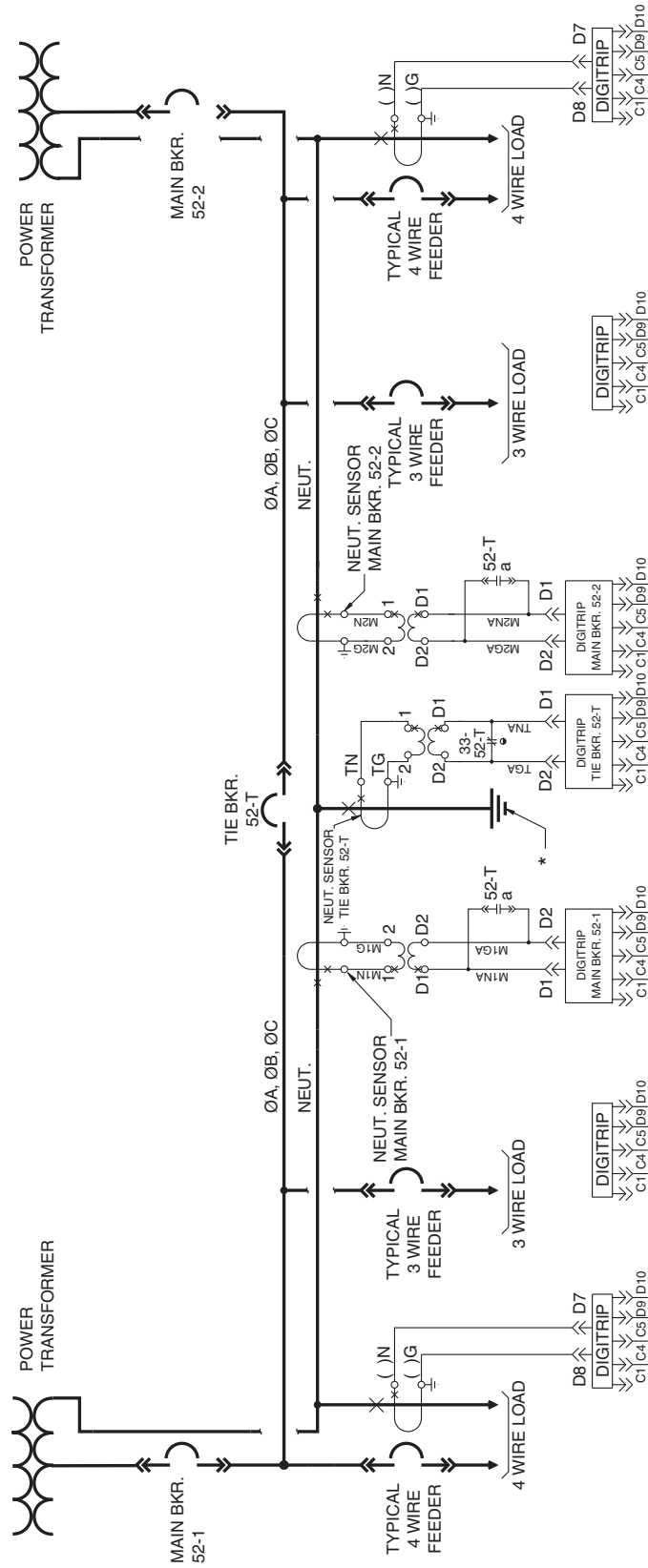

FIG. 11  
SINGLE LINE DIAGRAM  
OF SWITCHGEAR

\* NO OTHER GROUNDING OF NEUTRAL BUS SHOULD BE MADE  
UPSTREAM OR DOWNSTREAM FROM THIS POINT.

● BREAKER CELL SWITCH SHOWN WITH BREAKER IN THE TEST  
OR DISCONNECT POSITION.

<sup>2</sup>Zone interlocking not wired



# TEST PROCEDURE FOR: DOUBLE ENDED, 4 WIRE SYSTEM, SINGLE POINT GROUNDING “T” CONNECTION MAGNUM DS



DO NOT ATTEMPT TO TEST THIS EQUIPMENT WHILE IT IS ENERGIZED. DEATH OR SEVERE PERSONAL INJURY COULD RESULT. TURN OFF ALL POWER SUPPLYING THIS EQUIPMENT AND CHECK FOR VOLTAGE BEFORE TESTING.



DO NOT ATTEMPT TO TEST THIS EQUIPMENT WHILE IT IS ENERGIZED. DEATH OR SEVERE PERSONAL INJURY COULD RESULT. TURN OFF ALL POWER SUPPLYING THIS EQUIPMENT AND CHECK FOR VOLTAGE BEFORE TESTING.

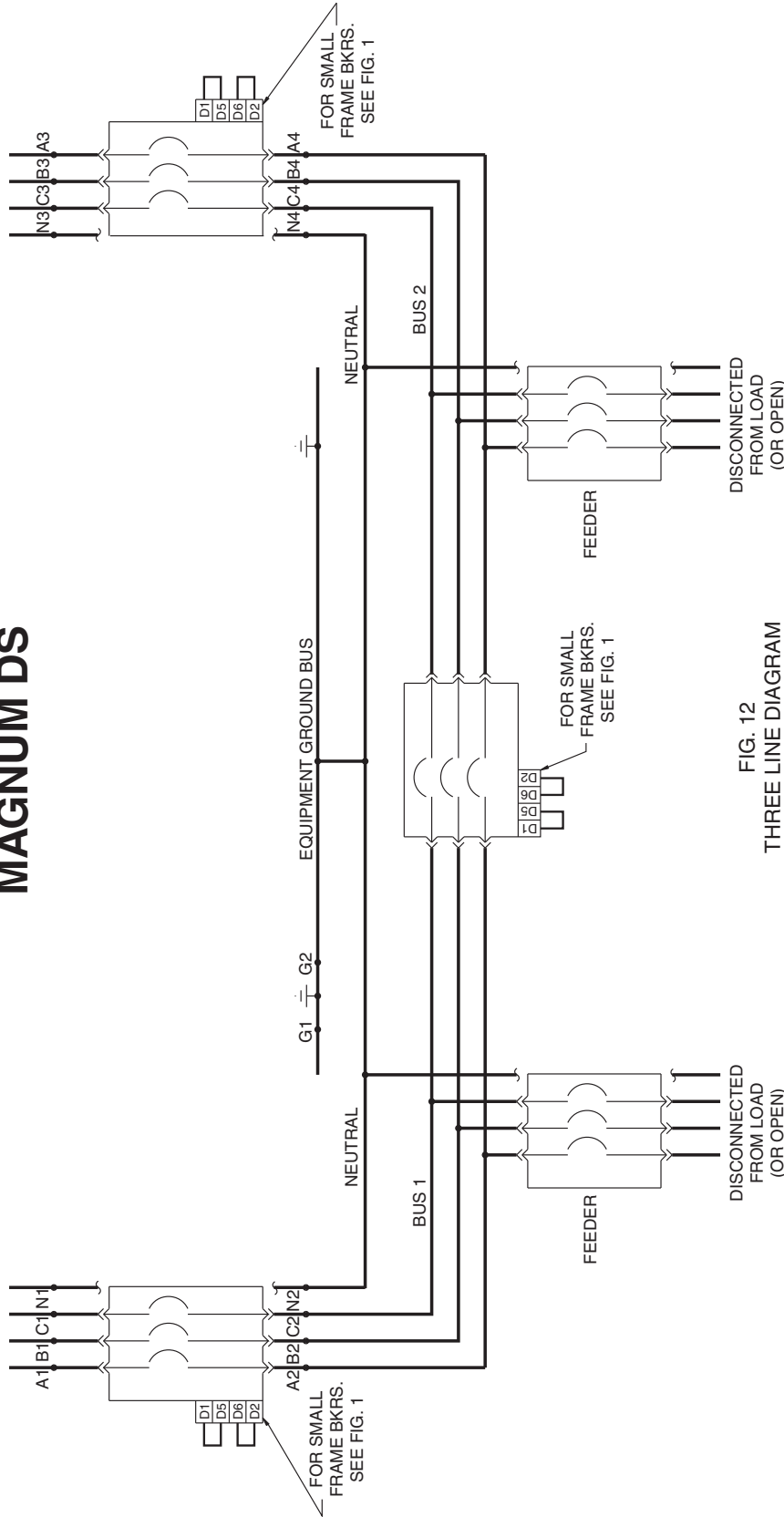

FIG. 12  
THREE LINE DIAGRAM  
INDICATING TEST POINTS

BREAKER STATUS	APPLY 1 <sup>0</sup>		INSTALL JUMPER FROM	RESULTS	REMARKS
	52-1	52-2			
CLOSED	OPEN	CLOSED	A2 & G2	MAIN 52-1 TRIPS	IF NO TRIP, CHECK CONN. AT 'D5' AND 'D6'
CLOSED	OPEN	OPEN	A1 & N1	TIE 52-T TRIPS, THEN MAIN 52-1 TRIPS	
CLOSED	CLOSED	OPEN	A2 & G2	TIE 52-T TRIPS	
CLOSED	CLOSED	OPEN	A4 & G2	TIE 52-T TRIPS	
CLOSED	OPEN	CLOSED	A4 & G2	MAIN 52-2 TRIPS	
OPEN	CLOSED	OPEN	A4 & G2	TIE 52-T TRIPS, THEN MAIN 52-2 TRIPS	
OPEN	CLOSED	CLOSED	A2 & G2	TIE 52-T TRIPS	

FOR FEEDER BREAKER TEST REFER TO PAGES 4 & 5  
REPEAT ALL OF THE ABOVE TESTS FOR 'B' PHASE & 'C' PHASE

**NOTE:** If any of the above tests do not pass, utilize Integral Test Panel<sup>®</sup> on Digitrip Unit to verify correct trip unit operation. If trip unit tests properly, check to see if incoming lines and loads are disconnected and that test power supply and jumper connections are correct.

<sup>0</sup>For Digitrip trip units without an integral test panel, use a Digitrip Test Kit for trip unit testing.

# TEST PROCEDURE FOR: DOUBLE ENDED, 4 WIRE SYSTEM, MODIFIED RESIDUAL GROUND FAULT

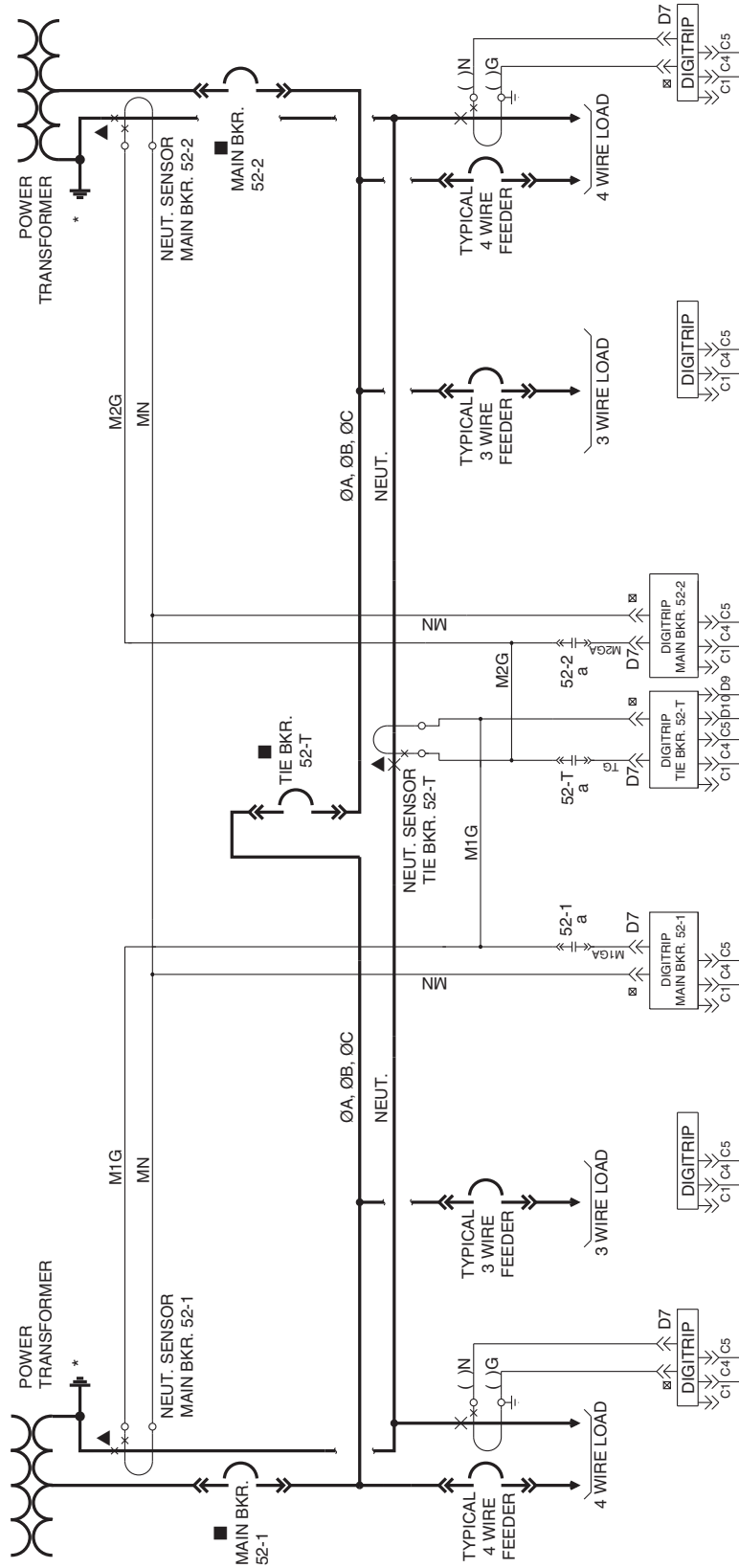

FIG. 15  
SINGLE LINE DIAGRAM  
OF SWITCHGEAR

- MAIN AND TIE BREAKERS MUST HAVE THE SAME FRAME AND SENSOR RATINGS, AND ONE OF THE THREE MUST BE NORMALLY OPEN.
- \* NO OTHER GROUNDING OF NEUTRAL BUS SHOULD BE MADE DOWNSTREAM FROM THESE TWO POINTS. TO DO SO WILL DEFEAT THE GROUND FAULT PROTECTION.

▲ POLARITY MUST BE AS SHOWN.

® Zone interlocking not wired

**⚠ DANGER**

DO NOT ATTEMPT TO TEST THIS EQUIPMENT WHILE IT IS ENERGIZED. DEATH OR SEVERE PERSONAL INJURY COULD RESULT. TURN OFF ALL POWER SUPPLYING THIS EQUIPMENT AND CHECK FOR VOLTAGE BEFORE TESTING.

**⚠ DANGER**

DO NOT ATTEMPT TO TEST THIS EQUIPMENT WHILE IT IS ENERGIZED. DEATH OR SEVERE PERSONAL INJURY COULD RESULT. TURN OFF ALL POWER SUPPLYING THIS EQUIPMENT AND CHECK FOR VOLTAGE BEFORE TESTING.

# TEST PROCEDURE FOR: DOUBLE ENDED, 4 WIRE SYSTEM, MODIFIED RESIDUAL GROUND FAULT

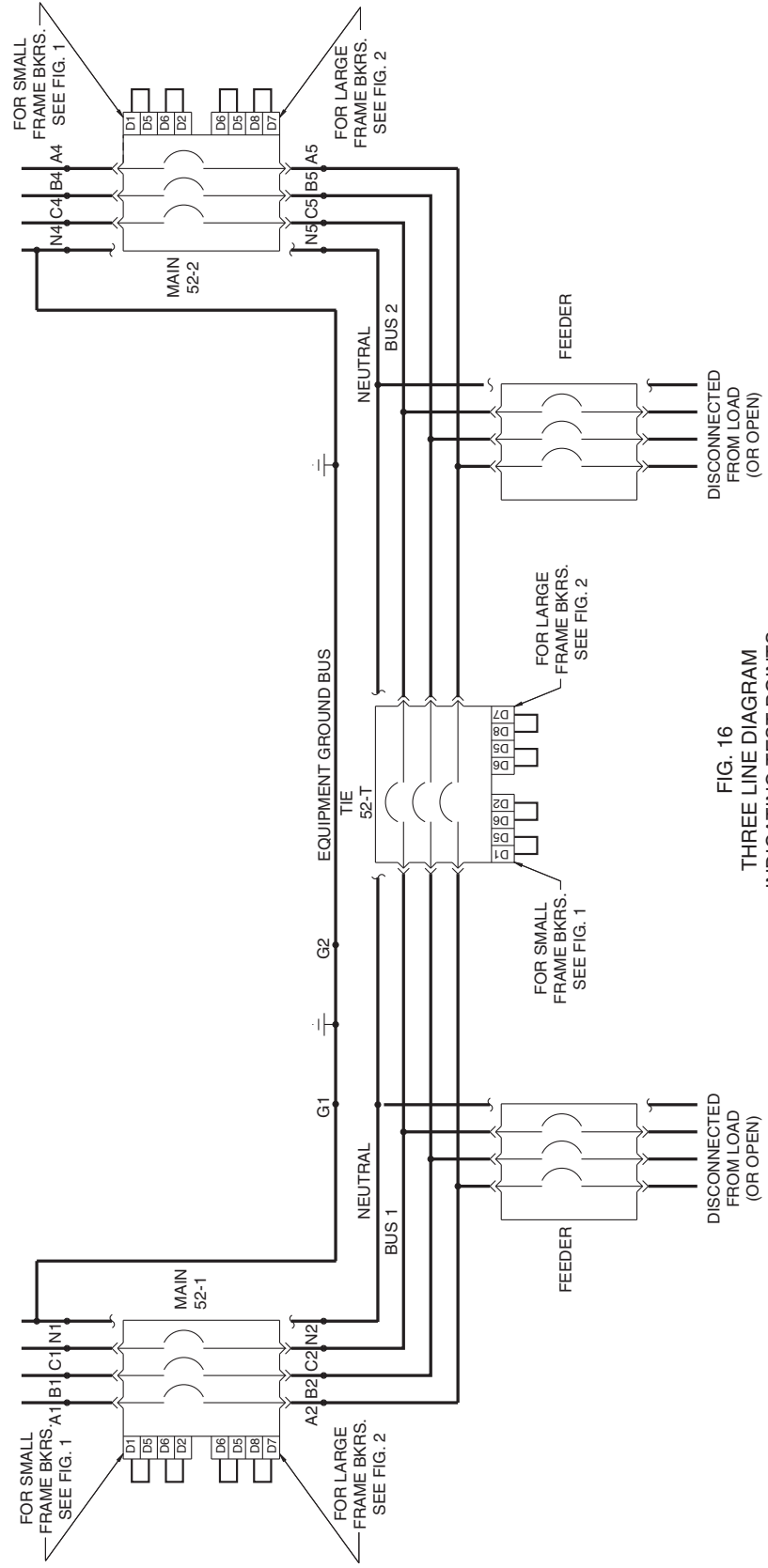

FIG. 16  
THREE LINE DIAGRAM  
INDICATING TEST POINTS

BREAKER STATUS		APPLY 1 <sup>o</sup> POWER TO	INSTALL JUMPER FROM	RESULTS	REMARKS
52-1	52-2	A1 & N1	A2 & N2	NO TRIP	POLARITY CHECK FOR MAIN 52-1 NEUTRAL SENSOR
CLOSED	CLOSED	A1 & N1	A4 & N4	NO TRIP	POLARITY CHECK FOR TIE 51-T NEUTRAL SENSOR
CLOSED	CLOSED	A3 & N3	A4 & N4	NO TRIP	POLARITY CHECK FOR MAIN 52-2 NEUTRAL SENSOR
CLOSED	CLOSED	A1 & N1	A2 & G2	MAIN 52-1 TRIPS	
CLOSED	CLOSED	A1 & N1	A4 & G2	TIE 52-T TRIPS	
CLOSED	CLOSED	A3 & N3	A4 & G2	MAIN 52-2 TRIPS	
OPEN	CLOSED	A3 & N3	A2 & G2	TIE 52-T TRIPS	

FOR FEEDER BREAKER TEST REFER TO PAGES 4 & 5  
REPEAT ALL OF THE ABOVE TESTS FOR 'B' PHASE & 'C' PHASE

**NOTE:** If any of the above tests do not pass, utilize Integral Test Panel<sup>®</sup> on Digitrip Unit to verify correct trip unit operation. If trip unit tests properly, check to see if incoming lines and loads are disconnected and that test power supply and jumper connections are correct.

If "No Trip" test fails, reverse secondary connections at neutral sensor and repeat test. If test still fails, check connections to Breaker at points B4 thru B9.

<sup>®</sup>For Digitrip trip units without an integral test panel, use a Digitrip Test Kit for trip unit testing.









This instruction booklet is published solely for information purposes and should not be considered all inclusive. If further information is required, you should consult Eaton.

Sale of product shown in this literature is subject to terms and conditions outlined in appropriate Eaton selling policies or other contractual agreement between the parties. This literature is not intended to and does not enlarge or add to any such contract. The sole source governing the rights and remedies of any purchaser of this equipment is the contract between the purchaser and Eaton.

**NO WARRANTIES, EXPRESSED OR IMPLIED, INCLUDING WARRANTIES OF FITNESS FOR A PARTICULAR PURPOSE OR MERCHANTABILITY, OR WARRANTIES ARISING FROM COURSE OF DEALING OR USAGE OF TRADE, ARE MADE REGARDING THE INFORMATION, RECOMMENDATIONS AND DESCRIPTIONS CONTAINED HEREIN.** In no event will Eaton be responsible to the purchaser or user in contract, in tort (including negligence), strict liability or otherwise for any special, indirect, incidental or consequential damage or loss whatsoever, including but not limited to damage or loss of use of equipment, plant or power system, cost of capital, loss of power, additional expenses in the use of existing power facilities, or claims against the purchase or user by its customers resulting from the use of the information, recommendations and descriptions contained herein.



221 Heywood Road  
Arden, NC 28704

---

Effective January 2011  
Printed in U.S.A./CCI

