

Undervoltage release in IZM low voltage circuit breakers

⚠ WARNING

(1) ONLY QUALIFIED ELECTRICAL PERSONNEL SHOULD BE PERMITTED TO WORK ON THE EQUIPMENT.
(2) ALWAYS DE-ENERGIZE PRIMARY AND SECONDARY CIRCUITS IF A CIRCUIT BREAKER CANNOT BE REMOVED TO A SAFE WORK LOCATION.
(3) DRAWOUT CIRCUIT BREAKERS SHOULD BE LEVERED (RACKED) OUT TO THE DISCONNECT POSITION.
(4) ALL CIRCUIT BREAKERS SHOULD BE SWITCHED TO THE OFF POSITION AND MECHANISM SPRINGS DISCHARGED.
FAILURE TO FOLLOW THESE STEPS FOR ALL PROCEDURES DESCRIBED IN THIS INSTRUCTION LEAFLET COULD RESULT IN DEATH, BODILY INJURY, OR PROPERTY DAMAGE.

Section 1: General information

The undervoltage release (UVR) opens the circuit breaker when its supply voltage falls to between 35–60% of rated voltage. If the release is not energized to 85% of its supply voltage, the circuit breaker cannot be closed electrically or manually.

Section 2: Installation of UVR

To install the UVR, proceed with the following six steps:

Step 1: Remove the front cover by unscrewing the hex-head captive bolts (four for three-pole, six for four-pole) that join the cover to the breaker housing using a 10 mm 1/4-inch drive socket. Then hold the charge handle down approximately 45 degrees to pull off the cover.

Step 2: Place the appropriate label on the front cover nameplate space located under "Accessories."

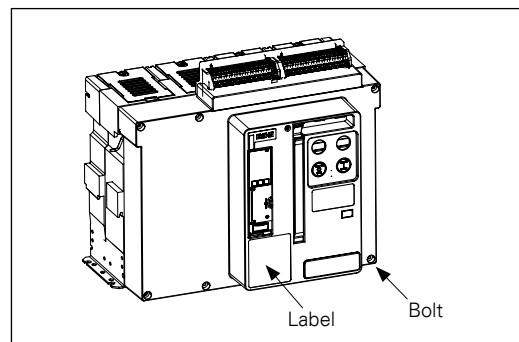

Figure 1. Steps 1 and 2

Step 3: Slide the lock on the UVR to the unlocked (up) position. Install the hook feet down through openings as shown. Then slide the UVR forward until the feet engage the mounting plate. Slide the lock down into the locked position.

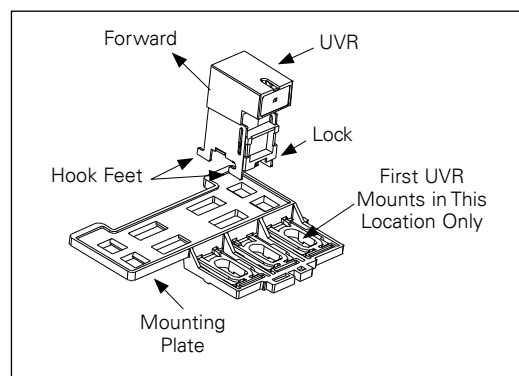

Figure 2. Step 3

EAT•N

Powering Business Worldwide

Step 4: Connect wires from the UVR to secondary contact positions 93 and 94, in keeping with markings on wires.

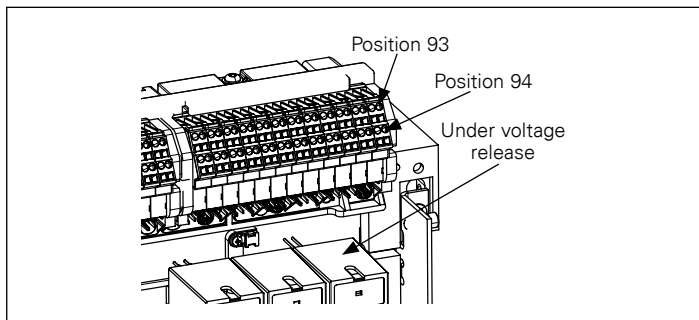

Figure 3. Step 4

Step 5: Reinstall front cover removed in Step 1.

Disclaimer of warranties and limitation of liability

The information, recommendations, descriptions, and safety notations in this document are based on Eaton Corporation's ("Eaton") experience and judgment, and may not cover all contingencies. If further information is required, an Eaton sales office should be consulted.

Sale of the product shown in this literature is subject to the terms and conditions outlined in appropriate Eaton selling policies or other contractual agreement between Eaton and the purchaser.

THERE ARE NO UNDERSTANDINGS, AGREEMENTS, WARRANTIES, EXPRESSED OR IMPLIED, INCLUDING WARRANTIES OF FITNESS FOR A PARTICULAR PURPOSE OR MERCHANTABILITY, OTHER THAN THOSE SPECIFICALLY SET OUT IN ANY EXISTING CONTRACT BETWEEN THE PARTIES. ANY SUCH CONTRACT STATES THE ENTIRE OBLIGATION OF EATON. THE CONTENTS OF THIS DOCUMENT SHALL NOT BECOME PART OF OR MODIFY ANY CONTRACT BETWEEN THE PARTIES.

In no event will Eaton be responsible to the purchaser or user in contract, in tort (including negligence), strict liability, or otherwise for any special, indirect, incidental, or consequential damage or loss whatsoever, including but not limited to damage or loss of use of equipment, plant or power system, cost of capital, loss of power, additional expenses in the use of existing power facilities, or claims against the purchaser or user by its customers resulting from the use of the information, recommendations, and descriptions contained herein.

The information contained in this manual is subject to change without notice.

Eaton Industries GmbH
Hein-Moeller-Straße 7-11,
53115 Bonn,
Germany
Eaton.com

© 2021 Eaton Industries GmbH
All Rights Reserved
Printed in Germany
Publication No. IL0131166EN
Effective December 2021