

Compact motor operator in IZM low voltage circuit breakers

⚠ WARNING

(1) ONLY QUALIFIED ELECTRICAL PERSONNEL SHOULD BE PERMITTED TO WORK ON THE EQUIPMENT.
(2) ALWAYS DE-ENERGIZE PRIMARY AND SECONDARY CIRCUITS IF A CIRCUIT BREAKER CANNOT BE REMOVED TO A SAFE WORK LOCATION.
(3) DRAWOUT CIRCUIT BREAKERS SHOULD BE LEVERED (RACKED) OUT TO THE DISCONNECT POSITION.
(4) ALL CIRCUIT BREAKERS SHOULD BE SWITCHED TO THE OFF POSITION AND MECHANISM SPRINGS DISCHARGED.
FAILURE TO FOLLOW THESE STEPS FOR ALL PROCEDURES DESCRIBED IN THIS INSTRUCTION LEAFLET COULD RESULT IN DEATH, BODILY INJURY, OR PROPERTY DAMAGE.

Section 1: General information

A motor operator is an electric motor assembly internally mounted in the circuit breaker. It charges the closing springs electrically for remote or local operation. The motor operator can be factory or site installed.

Required tools

- 1/4-inch drive socket wrench (with torque measuring capabilities)
- 10 mm socket
- 7/16-inch combination wrench
- Phillips head screwdriver (#2 recommended)
- 3/16-inch straight-blade screwdriver (eight inches long)

Kit parts identification

Refer to **Figure 1** for visual identification of the parts listed below:

- (A) Rear mounting bracket (one)—(not required for narrow frame breaker)
 (B) Motor operator (one)
 (C) Support pin (two)
 (D) M6 x 20 mm hex bolt (one)
 (E) M6 Helical lock washer (two)
 (F) M6 x 10 mm thread-forming screw (two)
 (G) Hi-lo screw #10 x 5/8 (two)
 (H) Thread-locking adhesive
 (I) Cable tie (four)
 (J) Accessory labels

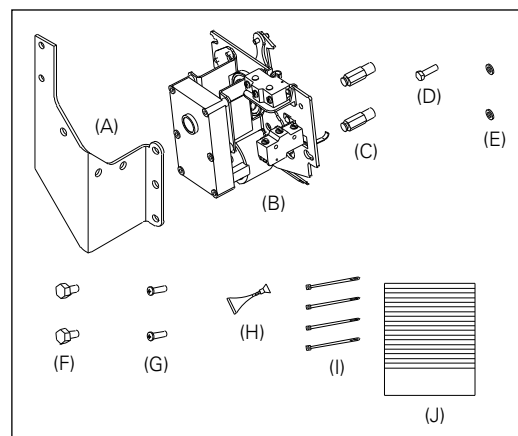

Figure 1. Contents of Kit

EAT•N

Powering Business Worldwide

Section 2: Installation of compact motor operator

Proceed with the following ten steps:

Step 1: Remove the front cover by unscrewing the hex-head captive bolts (four for three-pole, six for four-pole) that join the cover to the breaker housing using a 10 mm 1/4-inch drive socket. Then hold the charge handle down approximately 45 degrees to pull off the cover.

Step 2: Place the appropriate label (**J**) on the front cover nameplate space located under "Accessories."

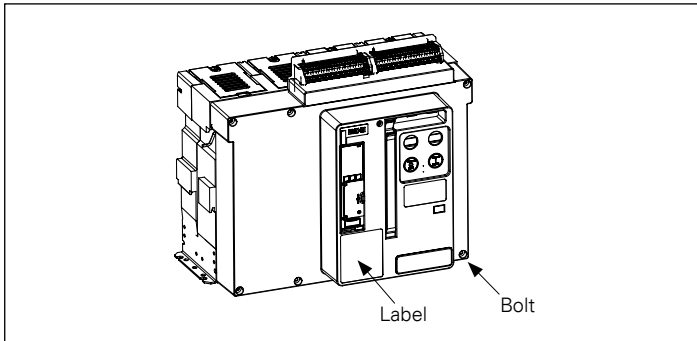

Figure 2. Steps 1 and 2

Step 3: Apply thread-locking adhesive (**H**) to the threads of and install two support pins (**C**) on the breaker as shown. Torque to 75–85 in-lbs (8.5–9.6 Nm).

Step 4: The motor operator (**B**) is now ready to be installed. To simplify this process, move the motor operator assembly toward the gears on the breaker with the pawl on the motor operator pulled back. Do not permit the motor operator plate to engage the support pins at this point. Move the motor operator in until the pawl is positively engaged with the gears. Now carefully slide the motor operator assembly back away from the breaker only far enough so the motor operator plate can engage the support pin grooves (in three places). Once the motor operator plate is engaged with the pins, slide the assembly all the way into the fixed position.

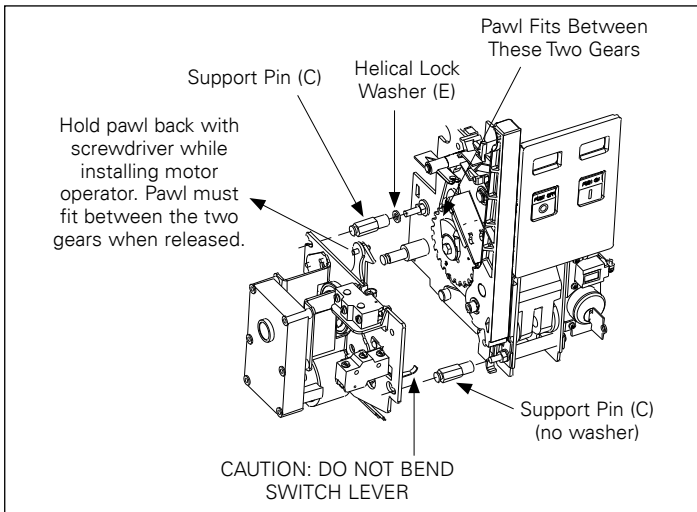

Figure 3. Steps 3 and 4

Step 5: Fasten the assembly with M6 x 20 mm bolt (**D**) and M6 helical lock washer (**E**). Torque to 75–85 in-lbs (8.5–9.6 Nm).

If the breaker is equipped with a levering device, verify that the levering interlock switch (if equipped) is centered on the levering device door tab. The switch should be closed when the levering device door is closed. The switch must be open when the door is open to access the levering drive socket.

For narrow frame breakers with 3.75-inch (95 mm) pole centers, proceed from here directly to Step 8.

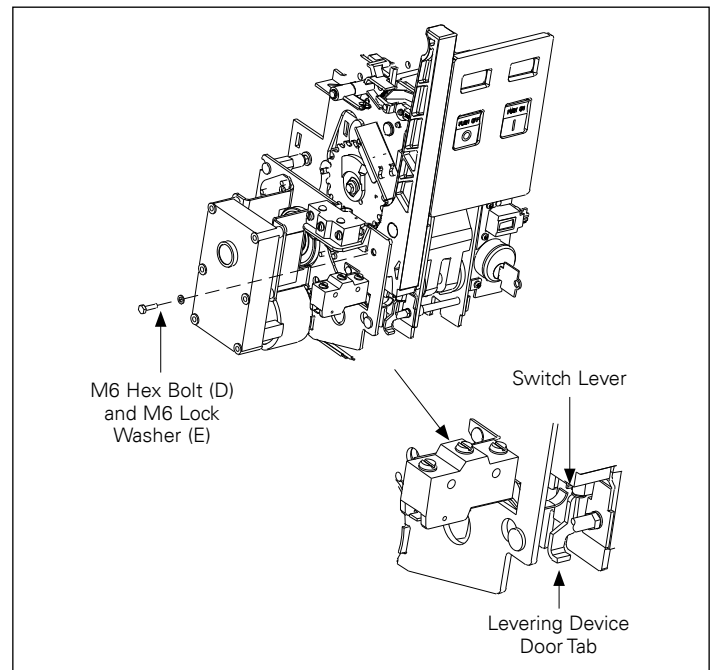

Figure 4. Step 5

Note: Steps 6 and 7 are required for standard frame breakers with 5.00-inch (127 mm) pole centers only, not narrow frame breakers.

Step 6: Mount plate to motor with two #10 x 5/8 long hi-lo screws (**G**). Torque to 18–22 in-lbs (2.0–2.5 Nm).

Step 7: Mount rear-mounting bracket (**A**) behind plate on breaker with two M6 x 10 mm long thread-forming screws (**F**).

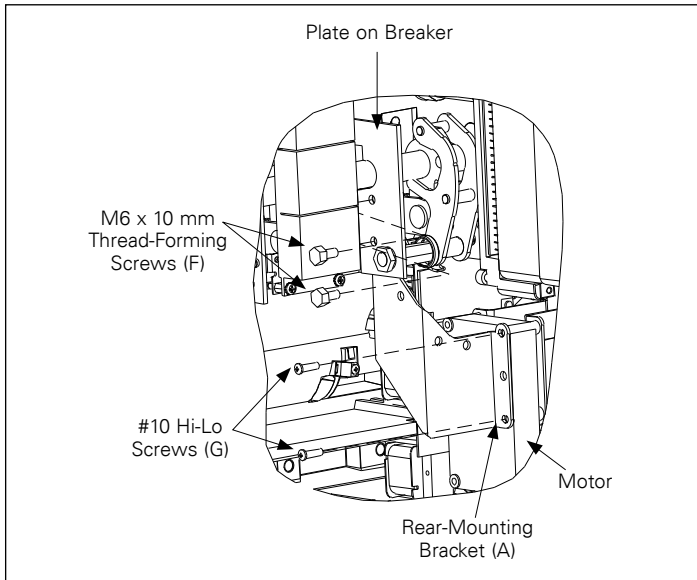

Figure 5. Steps 6 and 7

Step 8: Wire the motor operator leads with blue plugs to the secondary contacts block at terminal 1 and terminal 2 respectively (labeled E01+ and E02+). Wire the white motor lead to terminal 4 (labeled SC) on secondary terminals block.

If the breaker is a drawout breaker, proceed to Step 9 after completing Step 8. If the breaker is not a drawout breaker, proceed to Step 10 after completing Step 8.

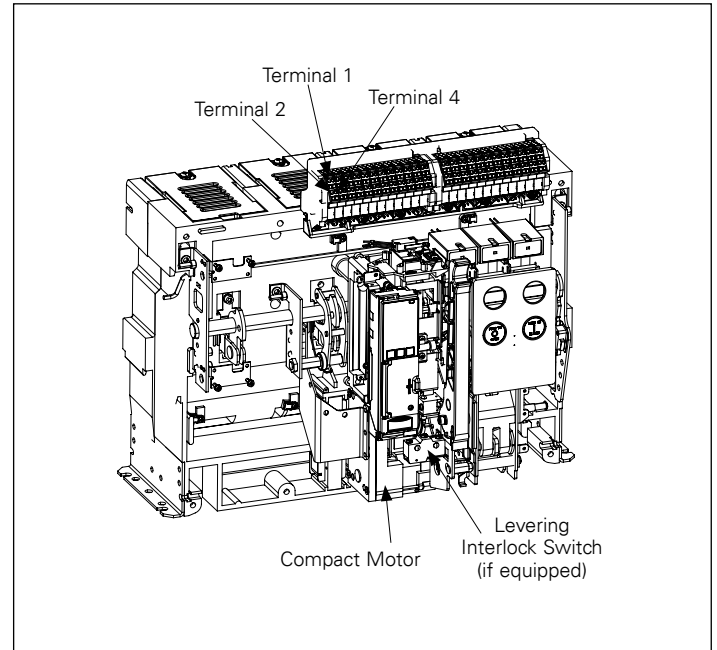

Figure 6. Step 8

Step 9: For drawout breaker only, check the levering interlock switch to verify that it opens when the levering access door is raised to a 0.40-inch gap. The switch must close when the door is lowered to a 0.10-inch gap.

Step 10: Reinstall front cover removed in Step 1.

Disclaimer of warranties and limitation of liability

The information, recommendations, descriptions, and safety notations in this document are based on Eaton Corporation's ("Eaton") experience and judgment, and may not cover all contingencies. If further information is required, an Eaton sales office should be consulted.

Sale of the product shown in this literature is subject to the terms and conditions outlined in appropriate Eaton selling policies or other contractual agreement between Eaton and the purchaser.

THERE ARE NO UNDERSTANDINGS, AGREEMENTS, WARRANTIES, EXPRESSED OR IMPLIED, INCLUDING WARRANTIES OF FITNESS FOR A PARTICULAR PURPOSE OR MERCHANTABILITY, OTHER THAN THOSE SPECIFICALLY SET OUT IN ANY EXISTING CONTRACT BETWEEN THE PARTIES. ANY SUCH CONTRACT STATES THE ENTIRE OBLIGATION OF EATON.

THE CONTENTS OF THIS DOCUMENT SHALL NOT BECOME PART OF OR MODIFY ANY CONTRACT BETWEEN THE PARTIES.

In no event will Eaton be responsible to the purchaser or user in contract, in tort (including negligence), strict liability, or otherwise for any special, indirect, incidental, or consequential damage or loss whatsoever, including but not limited to damage or loss of use of equipment, plant or power system, cost of capital, loss of power, additional expenses in the use of existing power facilities, or claims against the purchaser or user by its customers resulting from the use of the information, recommendations, and descriptions contained herein.

The information contained in this manual is subject to change without notice.

Eaton Industries GmbH
Hein-Moeller-Straße 7-11,
53115 Bonn,
Germany
Eaton.com

© 2021 Eaton Industries GmbH
All Rights Reserved
Printed in Germany
Publication No. IL0131169EN
Effective December 2021