

IP55 dust and water-resistant cover for IZM low voltage fixed or drawout circuit breaker

⚠ WARNING

(1) ONLY QUALIFIED ELECTRICAL PERSONNEL SHOULD BE PERMITTED TO WORK ON THE EQUIPMENT.

(2) ALWAYS DE-ENERGIZE PRIMARY AND SECONDARY CIRCUITS IF A CIRCUIT BREAKER CANNOT BE REMOVED TO A SAFE WORK LOCATION.

(3) DRAWOUT CIRCUIT BREAKERS SHOULD BE LEVERED (RACKED) OUT TO THE DISCONNECT POSITION.

(4) ALL CIRCUIT BREAKERS SHOULD BE SWITCHED TO THE OFF POSITION AND MECHANISM SPRINGS DISCHARGED.

FAILURE TO FOLLOW THESE STEPS FOR ALL PROCEDURES DESCRIBED IN THIS INSTRUCTION LEAFLET COULD RESULT IN DEATH, BODILY INJURY, OR PROPERTY DAMAGE.

Section 1: General information

The IP55 dust and water-resistant cover is a translucent hinged dome-shaped cover that attaches to the metal compartment door (panel) to provide dust and water protection for a drawout or fixed circuit breaker in keeping with the IP55 code. The specific code defines the degree of protection against the ingress of solid foreign objects and water.

Note: The IP55 cover is used in conjunction with a door escutcheon, which is a molded frame and gasket used to seal the space between the circuit breaker and the compartment door cutout. If an escutcheon is not already installed, an escutcheon kit will have to be installed before the IP55 cover can be used. The existing enclosure must qualify to IP55 requirements for dust and water environments.

Required tools

- Phillips head screwdriver (#2 recommended)
- Drill
- 0.265-inch (6.5 mm) drill bit
- Small adjustable wrench

Kit parts identification

Refer to **Figure 1** for visual identification of the parts listed below.

- (A) IP55 cover with captive hardware (one)
- (B) Hinge pin (one)
- (C) Hinge block (two)
- (D) Hex standoff (two)
- (E) M6 x 20 screw (four)
- (F) M6 x 8 screw (two)
- (G) M6 hex nut (four)
- (H) M6 split-ring lock washer (four)



Powering Business Worldwide

Effective December 2021

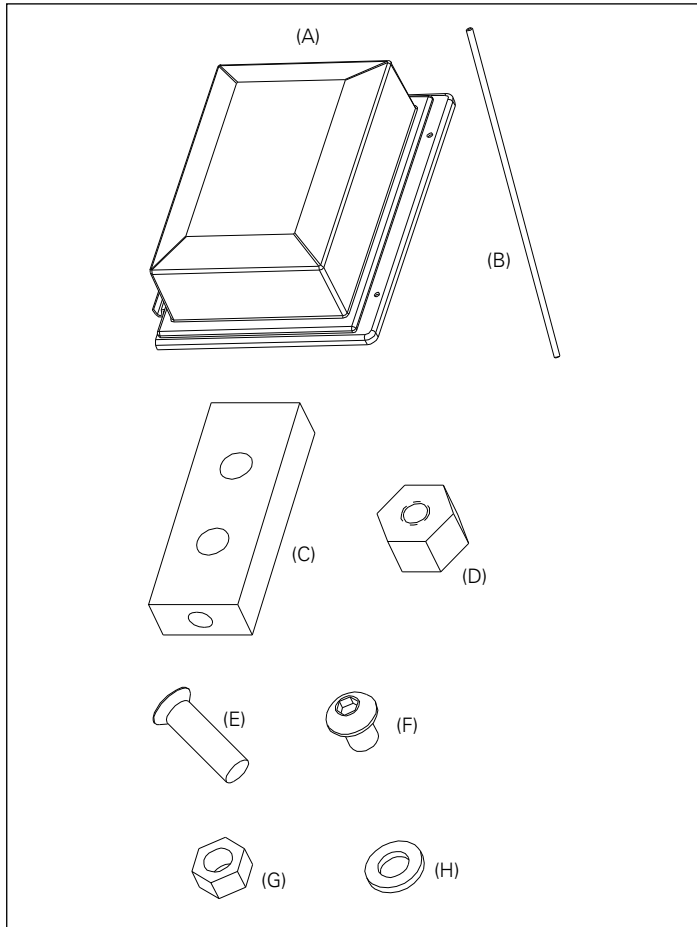

Figure 1. Contents of Kit Shown

Section 2: Installation of IP55 cover

Proceed with the following four steps.

Step 1: Locate and drill two 0.265-inch (6.5 mm) diameter mounting holes in the compartment door (panel) relative to the already mounted door escutcheon as shown for drawout or fixed-mounted circuit breakers.

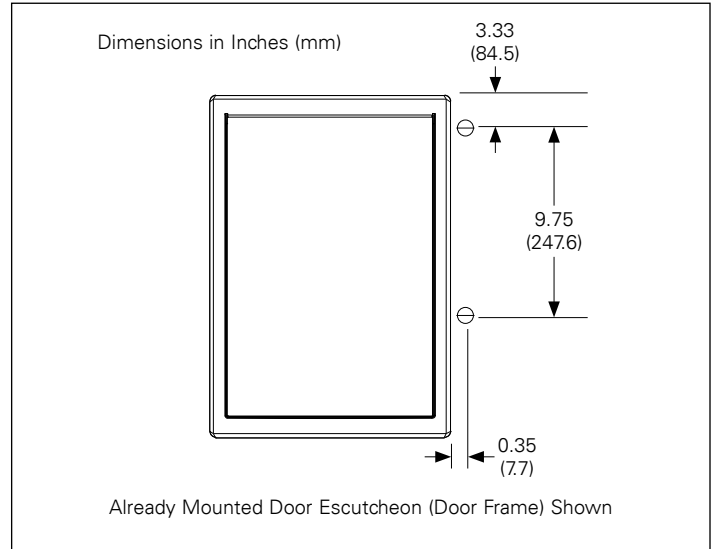

Figure 2. Step 1

Step 2: Mount the two hex standoffs (D) using M6 x 8 mm screws (F) from behind the compartment door (panel), using the holes from Step 1.

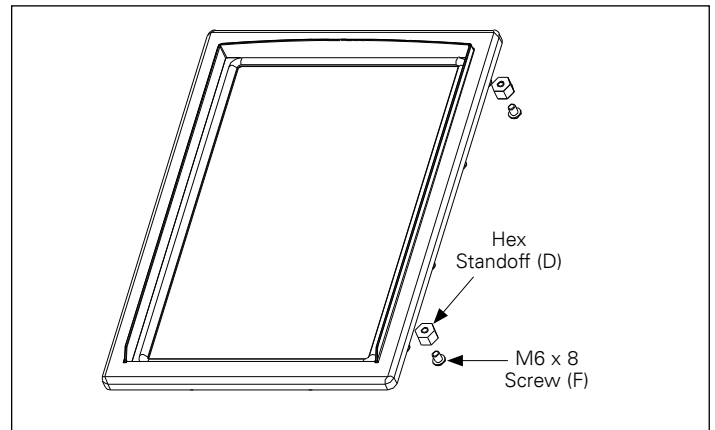

Figure 3. Step 2

Step 3: Mount the lexan IP55 cover (A) to the two hex standoffs installed in Step 2, using the captive hardware in the IP55 cover. This will ensure accurate positioning of the hardware to be installed next in Step 4.

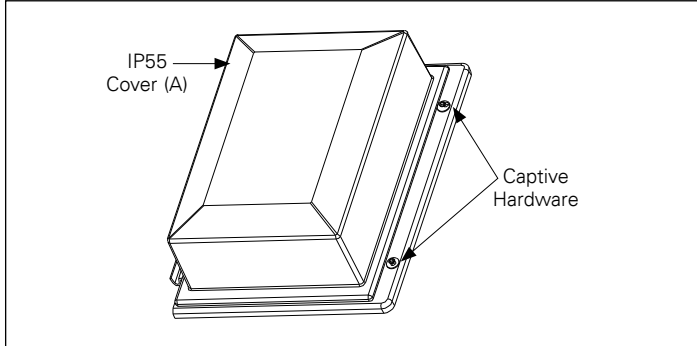

Figure 4. Step 3

Step 4: Align the lower hinge block (C) by centering hinge pin hole in the end of the hinge block with the hinge pin channel of the IP55 cover. The hinge block should be flush with the hinge channel of the cover. Use the two mounting holes of the block as a template to locate the placement of two 0.265 (6.5 mm) diameter holes in the compartment door (panel). Mount the lower hinge block using two M6 x 20 screws (E), M6 hex nuts (G) and M6 washers (H). The hex nuts and washers are positioned behind the compartment door (panel). Repeat the same procedure to mount the top hinge block, while capturing the hinge pin (B) in the end holes of the lower and upper hinge blocks.

Note: The IP55 cover is shown open in **Figure 5** below for clarity purposes.

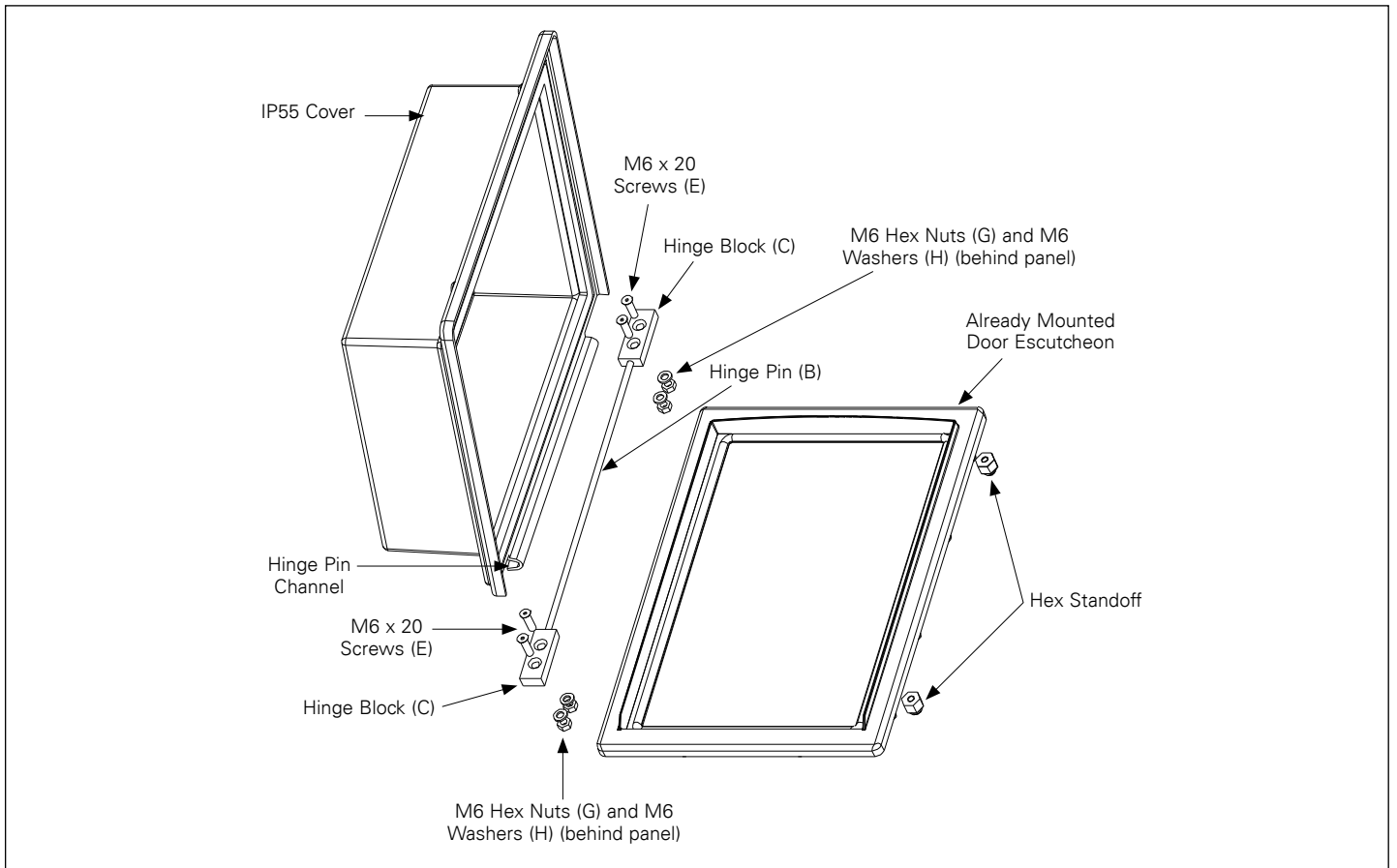

Figure 5. Step 4

Effective December 2021

Disclaimer of warranties and limitation of liability

The information, recommendations, descriptions, and safety notations in this document are based on Eaton Corporation's ("Eaton") experience and judgment, and may not cover all contingencies. If further information is required, an Eaton sales office should be consulted.

Sale of the product shown in this literature is subject to the terms and conditions outlined in appropriate Eaton selling policies or other contractual agreement between Eaton and the purchaser.

THERE ARE NO UNDERSTANDINGS, AGREEMENTS, WARRANTIES, EXPRESSED OR IMPLIED, INCLUDING WARRANTIES OF FITNESS FOR A PARTICULAR PURPOSE OR MERCHANTABILITY, OTHER THAN THOSE SPECIFICALLY SET OUT IN ANY EXISTING CONTRACT BETWEEN THE PARTIES. ANY SUCH CONTRACT STATES THE ENTIRE OBLIGATION OF EATON.

THE CONTENTS OF THIS DOCUMENT SHALL NOT BECOME PART OF OR MODIFY ANY CONTRACT BETWEEN THE PARTIES.

In no event will Eaton be responsible to the purchaser or user in contract, in tort (including negligence), strict liability, or otherwise for any special, indirect, incidental, or consequential damage or loss whatsoever, including but not limited to damage or loss of use of equipment, plant or power system, cost of capital, loss of power, additional expenses in the use of existing power facilities, or claims against the purchaser or user by its customers resulting from the use of the information, recommendations, and descriptions contained herein.

The information contained in this manual is subject to change without notice.

Eaton Industries GmbH
Hein-Moeller-Straße 7-11,
53115 Bonn,
Germany
Eaton.com

© 2021 Eaton Industries GmbH
All Rights Reserved
Printed in Germany
Publication No. IL0131181EN
Effective December 2021