

Low-voltage power distribution and control systems > Busway >

Busway—medium voltage

Contents

General Description	11.1-2
Overview	11.1-2
Standards	11.1-2
Construction Details	11.1-4
Fittings	11.1-8
Traditional Elbows	11.1-8
Offsets	11.1-9
Tees	11.1-10
Switchgear Flanges	11.1-11
End Cable Tap Box	11.1-12
Phase Transposition	11.1-12
Expansion Joints	11.1-13
Bushing Box Termination	11.1-13
Transformer Termination	11.1-14
Sealing Ring	11.1-14
Vapor Barriers	11.1-15
Fire Barriers	11.1-15
Column Supports	11.1-16
Horizontal Hanger	11.1-17
Wall/Floor Flange	11.1-19
Devices	11.1-20
Space Heaters	11.1-20
Layout	11.1-21
Installation Diagrams	11.1-21
Field Fit	11.1-22
Application Data	11.1-24
Electrical Data	11.1-24
Physical Data	11.1-25



EATON

Powering Business Worldwide



More about this product
[Eaton.com/busway](https://www.eaton.com/busway)



Complete library of design guides
[Eaton.com/designguides](https://www.eaton.com/designguides)

**Straight Section****Downward Elbow**

Overview

Eaton's non-segregated phase bus runs are designed for use on circuits whose importance requires greater reliability than power cables provide. Typical of such applications are the connections from transformers to switchgear assemblies in unit substations, connections from switchgear assemblies to rotating apparatus, and tie connections between switchgear assemblies.

Non-segregated phase bus is an assembly of bus conductors with associated connections, joints and insulating supports confined within a metal enclosure without interphase barriers. The conductors are adequately separated and insulated from each other and grounded by insulating bus supports. Each conductor for 635V service and above is insulated with a fluidized bed epoxy coating throughout, which reduces the possibility of corona and electrical tracking.

Standards

The metal-enclosed non-segregated phase bus runs are designed for 635V, 5 kV, 15 kV, 27 kV and 38 kV service in accordance with ANSI C37.23. Available ratings are shown in **Table 11.1-8**.

Temperature Rise

The bus will be capable of carrying rated current continuously without exceeding a conductor temperature rise of 65 °C above an outside ambient temperature of 40 °C, as required by ANSI Standard C37.23.

Test

The design of non-segregated bus runs has been tested per ANSI C37.23. Certification of momentary current testing, impulse testing and heat rise are available upon request.

Short-Circuit Current Withstand Ratings

The metal-enclosed non-segregated phase bus runs are designed to withstand electrical and mechanical forces generated by momentary (10 cycle) and short-time (2 second) short-circuit currents in accordance with the latest ANSI/IEEE® Standard C37.23. For 635V application, 4-cycle momentary current withstand rating up to 158 kA peak (98.8 kA rms asymmetrical) is also available.

Refer to **Table 11.1-8** for available short-circuit ratings.

Third-Party Certification

Certain bus ratings can be supplied with CSA® listing. Refer to **Table 11.1-8–Table 11.1-11** for availability of CSA listing

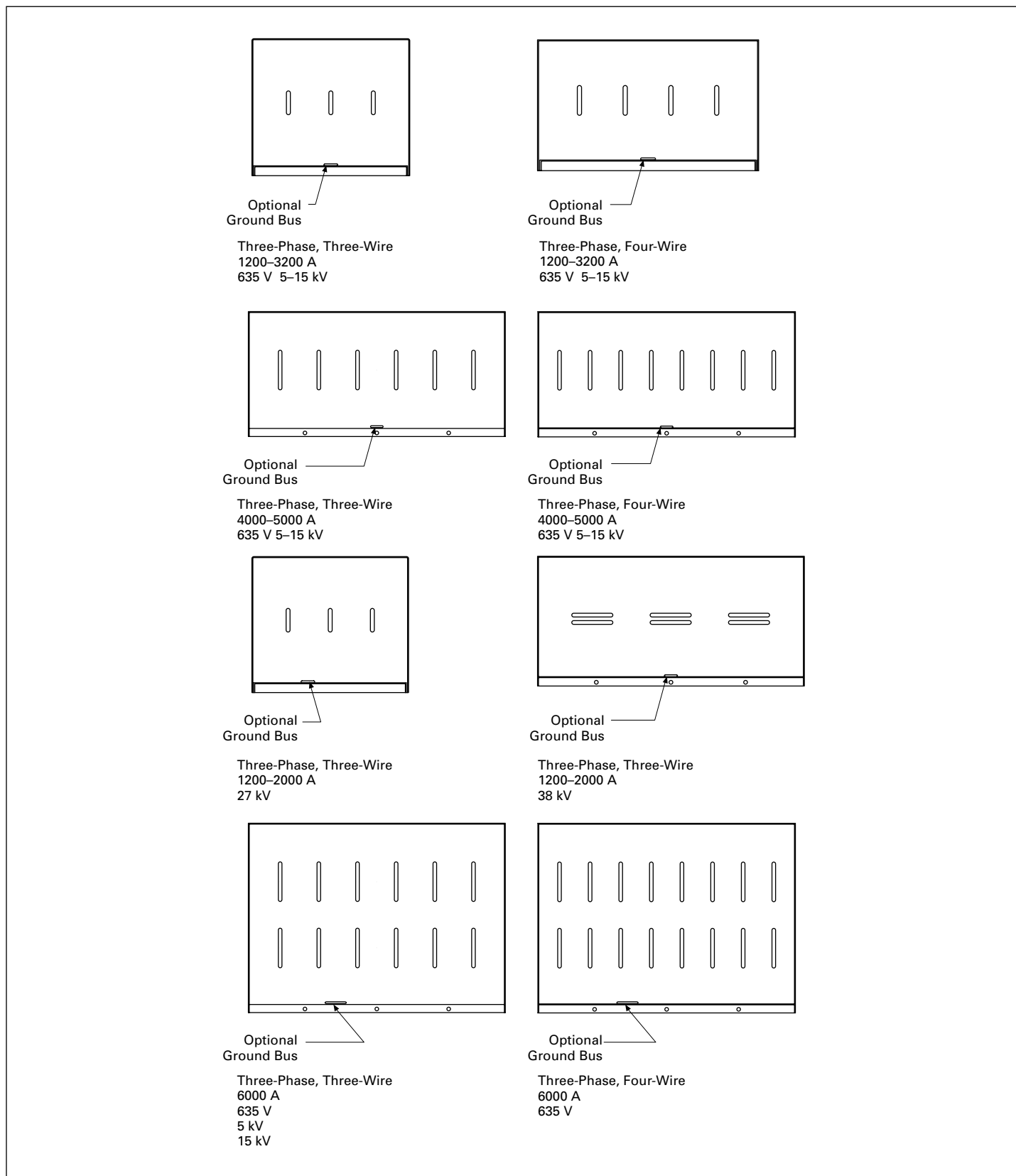

Figure 11.1-1. System Configurations

Construction Details

Collar

Collars (see **Figure 11.1-2**) are U-shaped metal pieces used for enclosure-to-enclosure connections. Size, shape of collar and number of bolts used will vary as per current rating.

Splice Joint

Conductors are silver-plated for maximum conductivity (tin plating is optional). Bus runs rated 3200 A (aluminum enclosure) or 2000 A (steel enclosure) and below use one conductor per phase, while the ratings up to 5000 A use two conductors per phase. Adjacent sections are electrically bonded together by means of plated copper splice plates to provide electrical continuity. All splice joints (see **Figure 11.1-3**) should be torqued 50 ft/lb. 6000 A rating uses four conductors per phase arranged in two rows with interleaved (1 2 3 1 2 3 for 3-wire and 1 2 3 4 1 2 3 4 for 4-wire) phase sequence. Bus bars of same phase in different rows are connected with splice plates at each bar end as shown in **Figure 11.1-4**.

Boot Connection

Bus joints are insulated with a flame-retardant PVC boot, easily removable for joint inspection (see **Figure 11.1-5**).

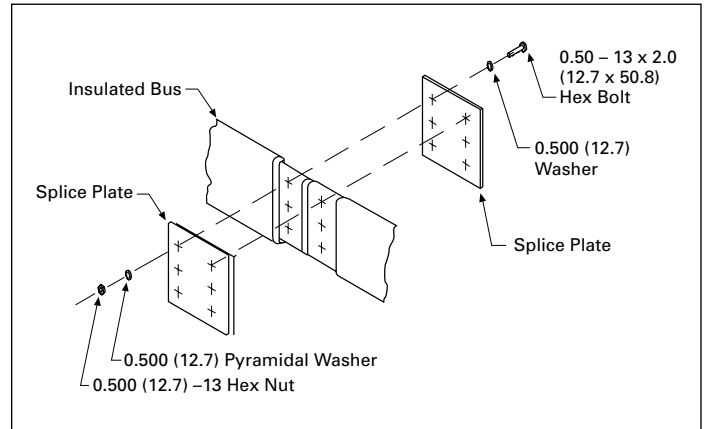

Figure 11.1-3. Typical Splice Plate Connection

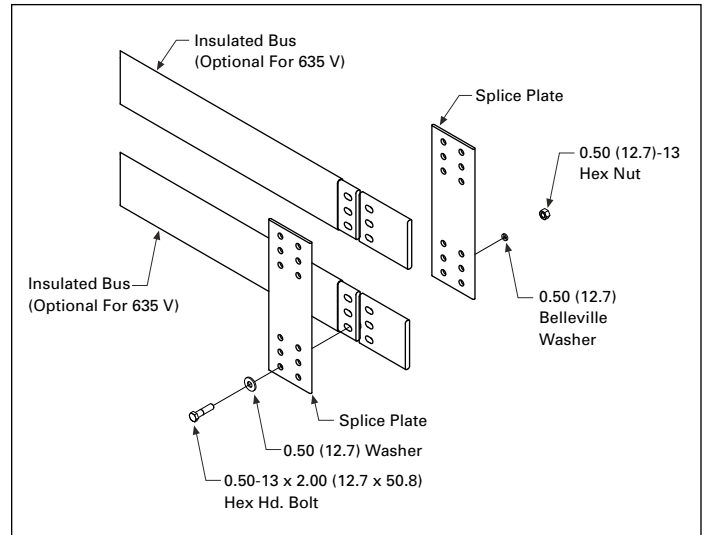

Figure 11.1-4. Double Bar Splice Plate Connection

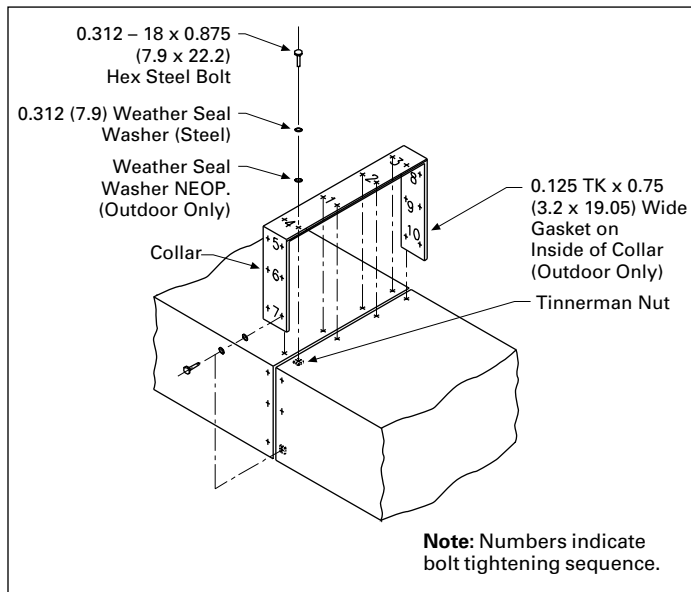

Figure 11.1-2. Enclosure Section Joint Collar

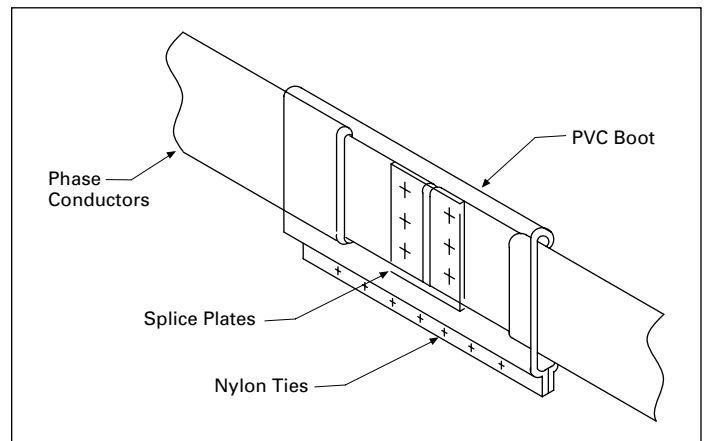

Figure 11.1-5. Boot Assembly (for Insulated Bus Only)

Enclosure

Enclosures are fabricated from 11-gauge aluminum, and are welded for maximum rigidity (see **Figure 11.1-6**). Removable covers are secured with bolts for ease of access when making joints and subsequent and periodic inspection. (Steel housings are also available.)

Enclosures are painted with baked-on epoxy powder coat paint system resulting in a very durable finish with uniform thickness and gloss. This cosmetically pleasing finish minimizes the risk of problems in harsh environments. The standard color is ANSI-61 light gray. Special paint colors are available upon request.

Flexible joints are supplied in all straight bus runs at approximately 50 feet (15.2 m) intervals to allow for the expected expansion when the conductors are energized and are carrying rated current.

A variety of terminations is available to accommodate most termination requirements. Bus runs can be terminated with flexible shunts, potheads, porcelain bushings or conductor stub ends for connections to riser bars in switchgear assemblies.

Phase Conductors

All conductors are 99% conductivity copper bars. Bus joints are made by solidly bolting the bus bars together with splice plates on each side (see **Figure 11.1-3**). All joint surfaces are silver-plated or tin-plated to ensure maximum conductivity through the joint. After bolting, each standard joint is covered by a preformed, flame-retardant insulating boot, providing full insulation for bus conductors rated 5 kV and above as standard and are optional on insulated conductors rated at 635 V (see **Figure 11.1-5**). These boots are easily removable for inspection of the joints at any future time. The copper bus bars are mounted on supports of track-resistant, flame-retardant glass polyester. If boots are not available for connection, taping the joint will be required (see **Figure 11.1-7**).

For flex connectors, finish connections with insulating tape (furnished). The following procedures should be followed for taping joints.

1. Clean area of dirt and foreign matter as specified under cleaning procedures.
2. Apply at least 1/8-inch (3.2 mm) of filler over the sharp edges of the conductor, splice plates, hardware or flex connectors. Smooth out and blend the contour so that tape may be easily applied.

3. Apply 3.00-inch (76.2 mm) insulating tape, lapping and layering (1 layer up to 5 kV) (2 layers for 5 kV to 15 kV). Tape must overlap pre-insulation by 1.50 inches (38.1 mm). Should a tape roll expire, start a new roll by overlapping any previous end by 1/2-turn.

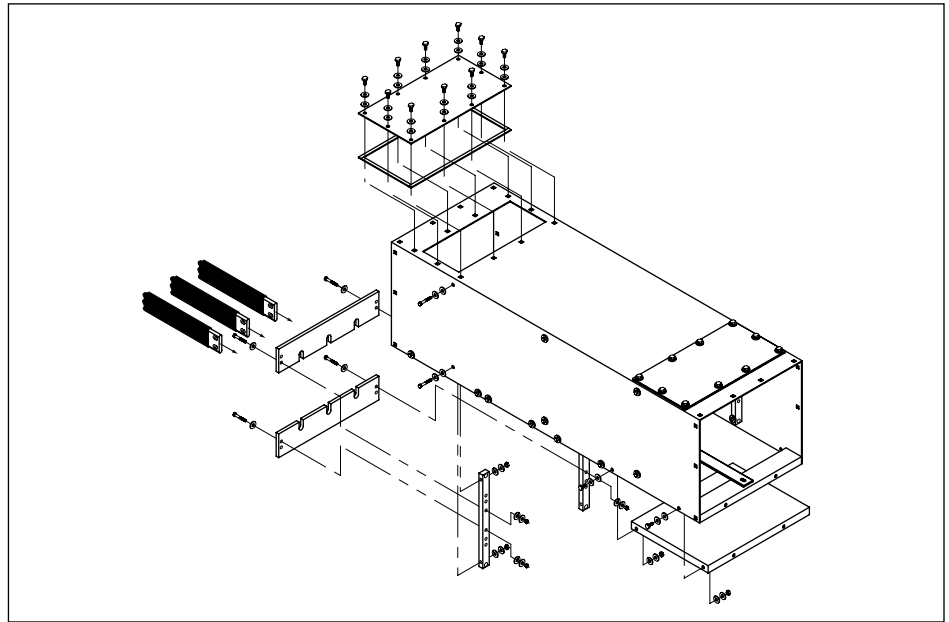

Figure 11.1-6. Housing Assembly

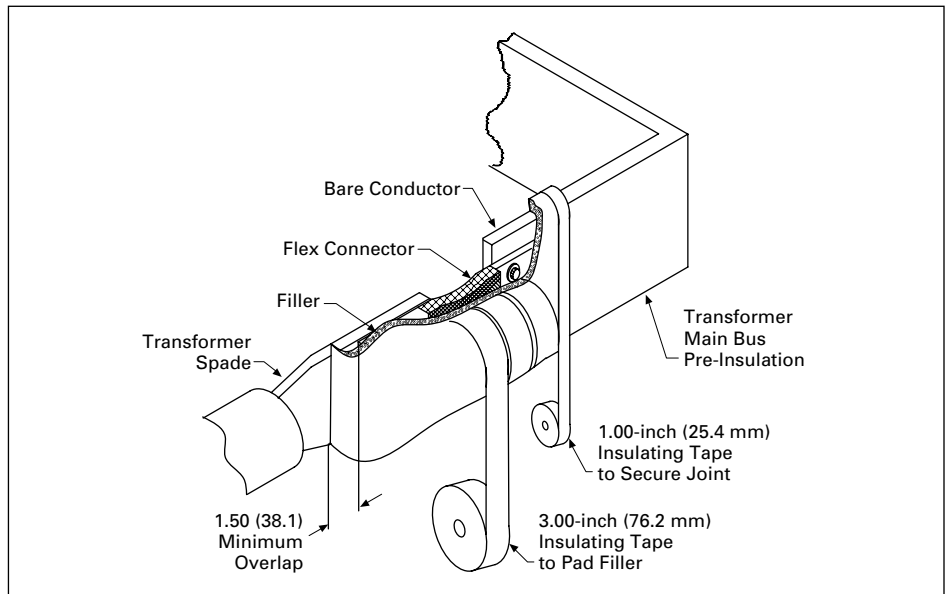

Figure 11.1-7. Taping Instructions

Ground Conductor (Optional)

For all ratings except 170 kA peak rated bus, a separate, continuous 0.25 x 2.00 inch (6.4 x 50.8 mm) uninsulated and plated copper ground bus, bolted and running along the entire length is available upon request. For 170 kA peak rated bus runs, a continuous 0.25 x 3.00 inch (6.4 x 76.2 mm) bare copper ground bus running along the entire length is provided when required.

In the 170 kA peak rated bus, ground pads are welded at each end of the enclosure. Copper ground links are provided (regardless of provisions of ground bus) to ensure a continuous ground path throughout the run.

Neutral Conductor (Optional)

Fully rated, isolated and insulated neutral conductor can be provided when specified.

Non-Segregated Phase Feeder Bus

Straight sections of feeder bus can be supplied in any length, at 1/4-inch (6.35 mm) increments, from a 24.00-inch (609.6 mm) minimum to an 8-foot (2.4 m) maximum. **Figure 11.1-8** illustrates the configuration of feeder bus and the conductor’s locations. Collars are used for all horizontal enclosure-to-enclosure connections.

Table 11.1-1. Enclosure Dimensions

Enclosure Width in Inches (mm)	Minimum Length in Inches (mm)	Maximum Length in Inches (mm)
20.00 (508.0)	24.00 (609.6)	96.00 (2438.4)
26.00 (660.4)	24.00 (609.6)	56.00 (1422.4)
35.75 (908.1)	24.00 (609.6)	56.00 (1422.4)

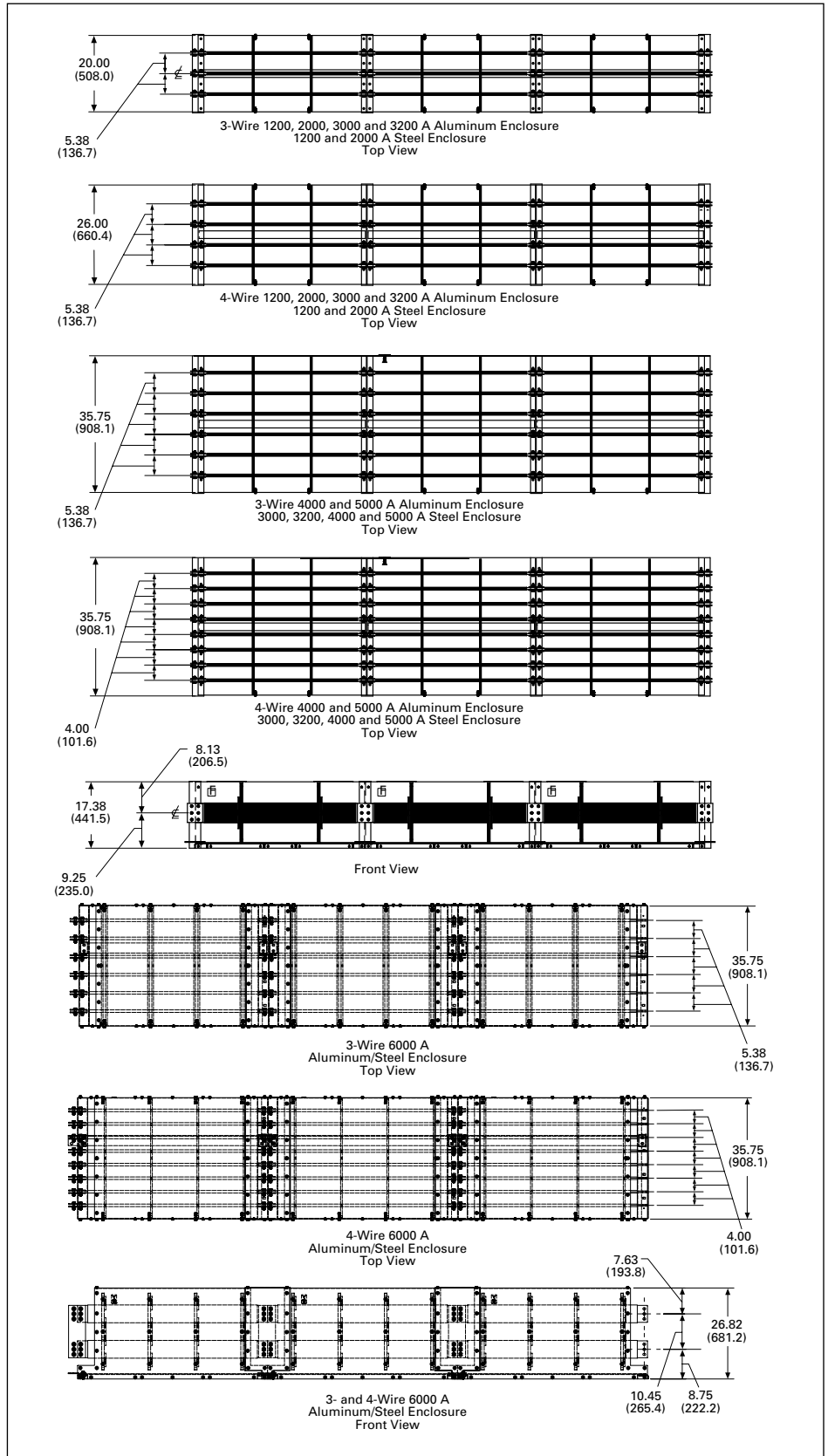

Figure 11.1-8. Non-Segregated Phase Feeder Bus

Vertical Feeder

Vertical feeder enclosures (see **Figure 11.1-9**) are designed in standard lengths of 24.00 inches (609.6 mm) through 56.00 inches (1422.4 mm) in 1.00-inch (25.4 mm) increments. All vertical enclosures are supplied with external (turned-out) flanges for enclosure-to-enclosure connections.

Dust-Proof Construction

Both vertical and horizontal sections of feeder bus can be supplied with dust-proof construction in any length, at 1/4-inch (6.35 mm) increments, from 24.00 inches (609.6 mm) to an 8-foot (2.4 m) maximum. **Figure 11.1-9** illustrates the configuration of feeder bus and the conductor's locations. Removable gasket flat covers are secured with bolts for ease of access when making joints and subsequent and periodic inspection. External and internal flanges are used for all dust-proof enclosure-to-enclosure connections. Gasket material is to be placed between internal and external flanges during installation.

Fittings

There is a fitting to meet every application need: flanges, elbows, offsets, tees, cable tap boxes, transformer connections and expansion joints. These fittings, along with standard and minimum dimensions, are described on the following pages.

The relationship of fittings to straight lengths (forward, rearward, upward and downward) is illustrated in **Figure 11.1-11**.

When making field measurements and layouts, it should be remembered that the dimensions are given from the centerline of the non-segregated bus bar, not the centerline of the housing. **Figure 11.1-10** and **Figure 11.1-11** show the differences in center line in relationship to the housing.

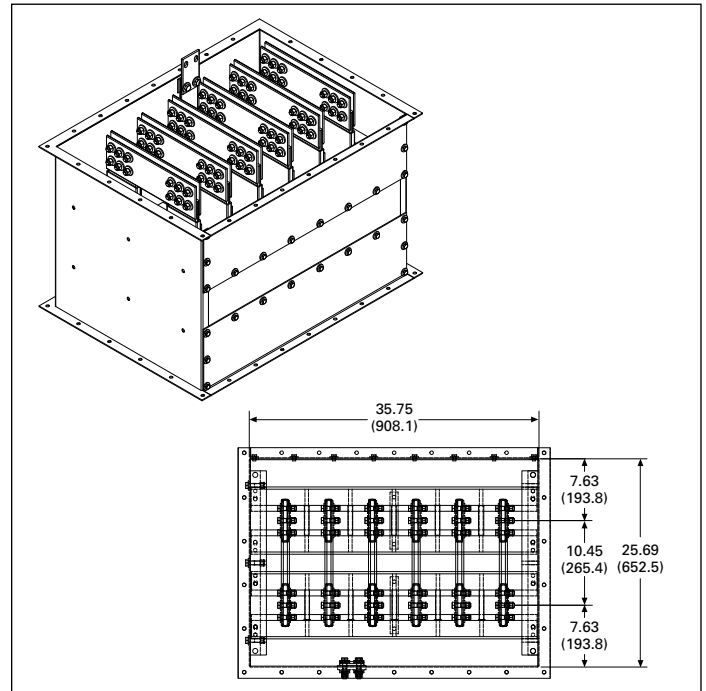

Figure 11.1-10. 6000 A Vertical Feeder and Dustproof Construction

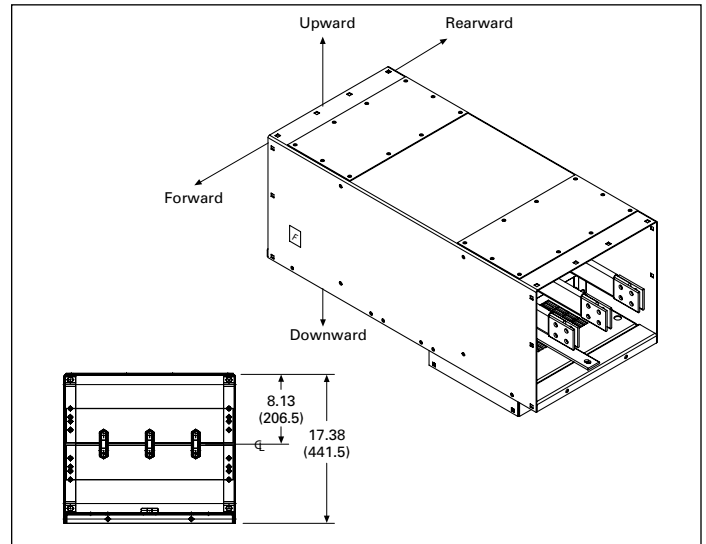

Figure 11.1-11. Horizontal Feeder Non-Dustproof

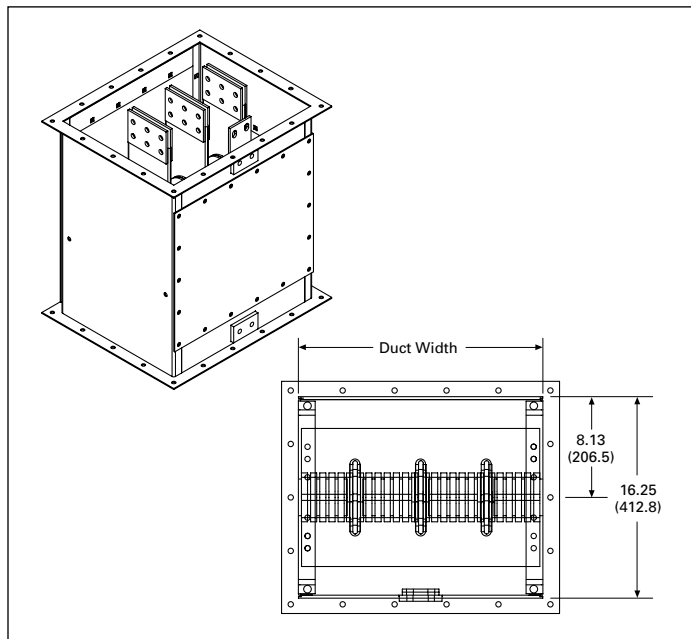

Figure 11.1-9. Vertical Feeder and Dustproof Construction

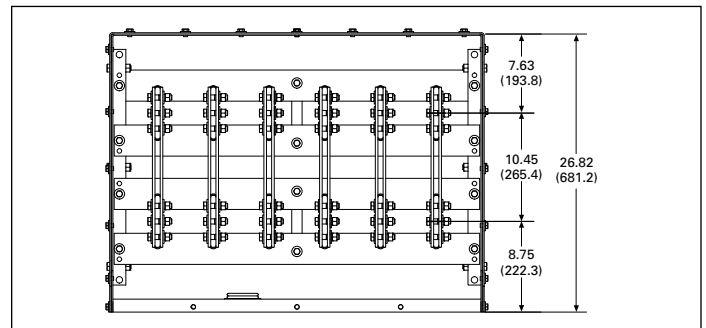

Figure 11.1-12. 6000 A Horizontal Feeder Non-Dustproof

Traditional Elbows

Elbows are used to make 90-degree changes in the direction of bus runs. The four types that are available are forward, rearward, upward and downward.

Table 11.1-2. Elbow Dimensions

Amperes	Wire Type	Enclosure Material	Dimensions in Inches (mm)							
			Upward		Downward		Rearward		Forward	
			A	B	A	B	A	B	A	B
1200	3	Aluminum/steel	17.00 (431.8)	19.25 (489.0)	18.00 (457.2)	19.25 (489.0)	21.00 (533.4)	21.00 (533.4)	21.00 (533.4)	21.00 (533.4)
2000	3	Aluminum/steel	17.00 (431.8)	19.25 (489.0)	18.00 (457.2)	19.25 (489.0)	21.00 (533.4)	21.00 (533.4)	21.00 (533.4)	21.00 (533.4)
3000	3	Aluminum	17.00 (431.8)	19.25 (489.0)	18.00 (457.2)	19.25 (489.0)	21.00 (533.4)	21.00 (533.4)	21.00 (533.4)	21.00 (533.4)
3000	3	Steel	17.00 (431.8)	19.25 (489.0)	18.00 (457.2)	19.25 (489.0)	21.00 (736.6)	21.00 (533.4)	21.00 (533.4)	21.00 (533.4)
3200	3	Aluminum	17.00 (431.8)	19.25 (489.0)	18.00 (457.2)	19.25 (489.0)	21.00 (533.4)	21.00 (533.4)	21.00 (533.4)	21.00 (533.4)
3200	3	Steel	17.00 (431.8)	19.25 (489.0)	18.00 (457.2)	19.25 (489.0)	21.00 (736.6)	21.00 (533.4)	21.00 (533.4)	21.00 (533.4)
4000	3	Aluminum/steel	17.00 (431.8)	19.25 (489.0)	18.00 (457.2)	19.25 (489.0)	29.00 (736.6)	29.00 (736.6)	29.00 (736.6)	29.00 (736.6)
5000	3	Aluminum/steel	17.00 (431.8)	19.25 (489.0)	18.00 (457.2)	19.25 (489.0)	29.00 (736.6)	29.00 (736.6)	29.00 (736.6)	29.00 (736.6)
6000	3	Aluminum/steel	25.24 (641.1)	25.85 (656.6)	26.40 (670.6)	25.85 (656.6)	30.90 (784.9)	30.90 (784.9)	30.90 (784.9)	30.90 (784.9)
1200	4	Aluminum/steel	17.00 (431.8)	19.25 (489.0)	18.00 (457.2)	19.25 (489.0)	24.00 (609.6)	24.00 (609.6)	24.00 (609.6)	24.00 (609.6)
2000	4	Aluminum/steel	17.00 (431.8)	19.25 (489.0)	18.00 (457.2)	19.25 (489.0)	24.00 (609.6)	24.00 (609.6)	24.00 (609.6)	24.00 (609.6)
3000	4	Aluminum	17.00 (431.8)	19.25 (489.0)	18.00 (457.2)	19.25 (489.0)	24.00 (609.6)	24.00 (609.6)	24.00 (609.6)	24.00 (609.6)
3000	4	Steel	17.00 (431.8)	19.25 (489.0)	18.00 (457.2)	19.25 (489.0)	24.00 (609.6)	24.00 (609.6)	24.00 (609.6)	24.00 (609.6)
3200	4	Aluminum	17.00 (431.8)	19.25 (489.0)	18.00 (457.2)	19.25 (489.0)	24.00 (609.6)	24.00 (609.6)	24.00 (609.6)	24.00 (609.6)
3200	4	Steel	17.00 (431.8)	19.25 (489.0)	18.00 (457.2)	19.25 (489.0)	24.00 (609.6)	24.00 (609.6)	24.00 (609.6)	24.00 (609.6)
4000	4	Aluminum/steel	17.00 (431.8)	19.25 (489.0)	18.00 (457.2)	19.25 (489.0)	24.00 (609.6)	24.00 (609.6)	24.00 (609.6)	24.00 (609.6)
5000	4	Aluminum/steel	17.00 (431.8)	19.25 (489.0)	18.00 (457.2)	19.25 (489.0)	29.00 (736.6)	29.00 (736.6)	29.00 (736.6)	29.00 (736.6)
6000	4	Aluminum/steel	25.24 (641.1)	25.85 (656.6)	26.40 (670.6)	25.85 (656.6)	30.90 (784.9)	30.90 (784.9)	30.90 (784.9)	30.90 (784.9)

Note: All dimensions are to the centerline of the non-segregated bus bar.

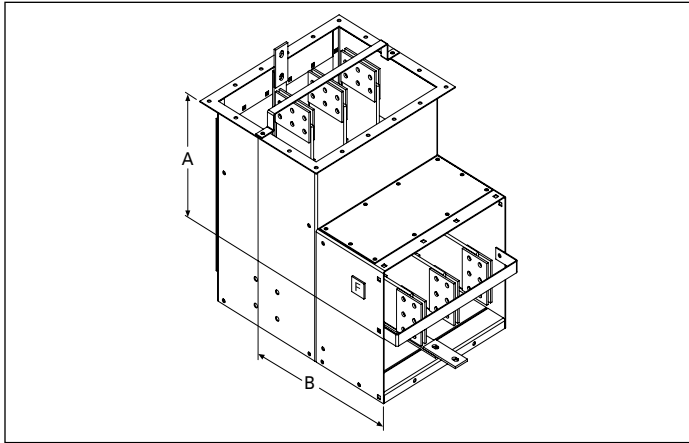

Figure 11.1-13. Upward Elbow

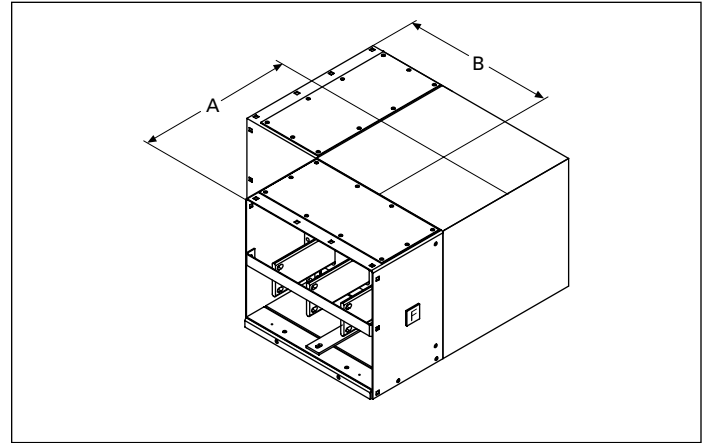

Figure 11.1-15. Rearward Elbow

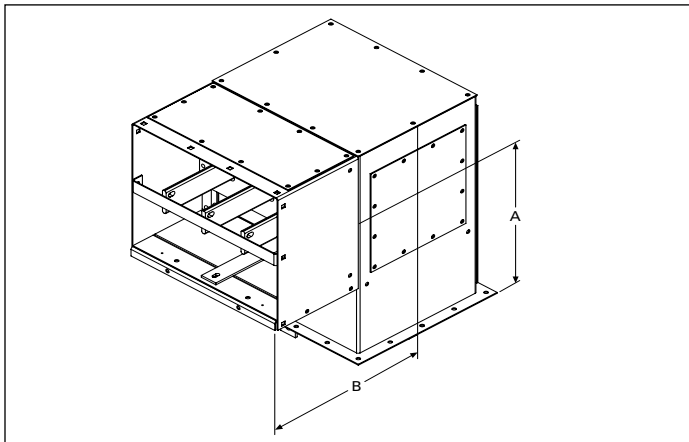

Figure 11.1-14. Downward Elbow

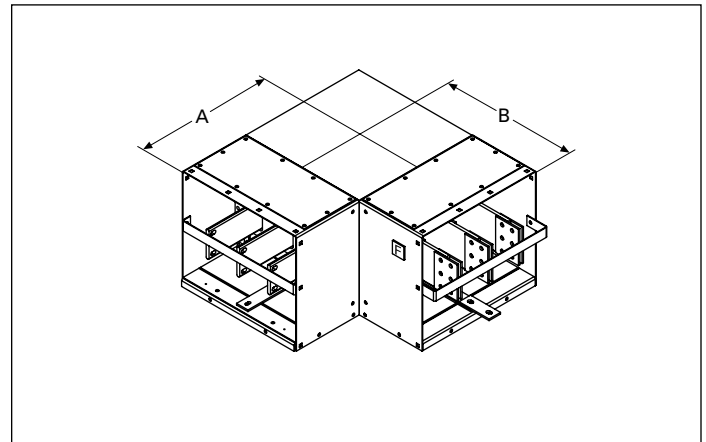

Figure 11.1-16. Forward Elbow

Offsets

An offset is used to avoid obstacles and to conform to building structure. It is two elbows fabricated into a single fitting for use where space restrictions prohibit the use of a standard 90-degree elbow. The minimum lengths are listed in **Table 11.1-3**.

Table 11.1-3. Offset Dimensions

Amperes	Wire Type	Enclosure Material	Dimensions in Inches (mm)			
			Upward	Downward	Rearward	Forward
			A	A	A	A
1200	3	Aluminum/steel	19.25 (489.0)	19.25 (489.0)	21.00 (533.4)	21.00 (533.4)
2000	3	Aluminum/steel	19.25 (489.0)	19.25 (489.0)	21.00 (533.4)	21.00 (533.4)
3000	3	Aluminum	19.25 (489.0)	19.25 (489.0)	21.00 (533.4)	21.00 (533.4)
3000	3	Steel	19.25 (489.0)	19.25 (489.0)	21.00 (533.4)	21.00 (533.4)
3200	3	Aluminum	19.25 (489.0)	19.25 (489.0)	21.00 (533.4)	21.00 (533.4)
3200	3	Steel	19.25 (489.0)	19.25 (489.0)	21.00 (533.4)	21.00 (533.4)
4000	3	Aluminum/steel	19.25 (489.0)	19.25 (489.0)	29.00 (736.6)	29.00 (736.6)
5000	3	Aluminum/steel	19.25 (489.0)	19.25 (489.0)	29.00 (736.6)	29.00 (736.6)
6000	3	Aluminum/steel	25.85 (656.6)	25.85 (656.6)	30.90 (784.9)	30.90 (784.9)
1200	4	Aluminum/steel	19.25 (489.0)	19.25 (489.0)	24.00 (609.6)	24.00 (609.6)
2000	4	Aluminum/steel	19.25 (489.0)	19.25 (489.0)	24.00 (609.6)	24.00 (609.6)
3000	4	Aluminum	19.25 (489.0)	19.25 (489.0)	24.00 (609.6)	24.00 (609.6)
3000	4	Steel	19.25 (489.0)	19.25 (489.0)	24.00 (609.6)	24.00 (609.6)
3200	4	Aluminum	19.25 (489.0)	19.25 (489.0)	24.00 (609.6)	24.00 (609.6)
3200	4	Steel	19.25 (489.0)	19.25 (489.0)	24.00 (609.6)	24.00 (609.6)
4000	4	Aluminum/steel	19.25 (489.0)	19.25 (489.0)	29.00 (736.6)	29.00 (736.6)
5000	4	Aluminum/steel	19.25 (489.0)	19.25 (489.0)	29.00 (736.6)	29.00 (736.6)
6000	4	Aluminum/steel	25.85 (656.6)	25.85 (656.6)	30.90 (784.9)	30.90 (784.9)

Note: All dimensions are to the centerline of the non-segregated bus bar.

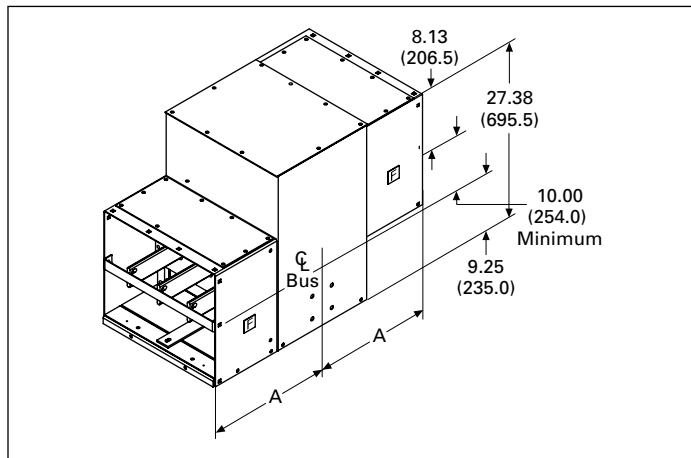

Figure 11.1-17. Upward Offset

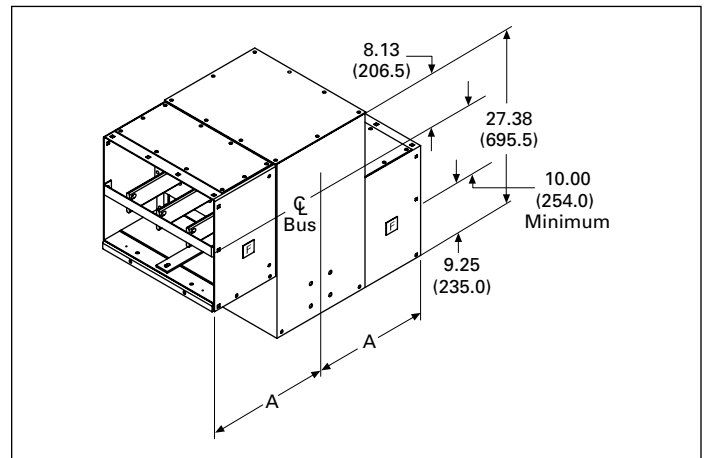

Figure 11.1-19. Downward Offset

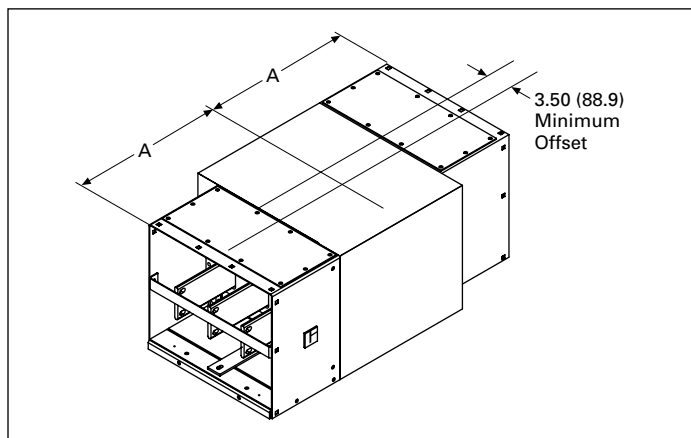

Figure 11.1-18. Rearward Offset

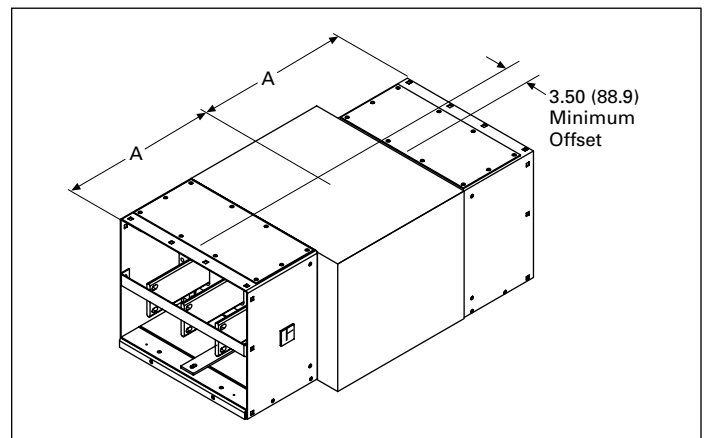

Figure 11.1-20. Forward Offset

Tees

Tees are used to branch-off a bus run. The four types available are forward, rearward, upward and downward.

Table 11.1-4. Tee Dimensions

Amperes	Dimensions in Inches (mm)				
	A	B	C	D	E
5000 and below	19.25 (489.0)	18.00 (457.2)	17.00 (431.8)	29.00 (736.6)	17.38 (441.5)
6000	25.85 (656.6)	26.40 (670.6)	25.24 (641.1)	30.90 (784.9)	26.82 (681.2)

Note: All dimensions are to the centerline of the non-segregated bus bar.

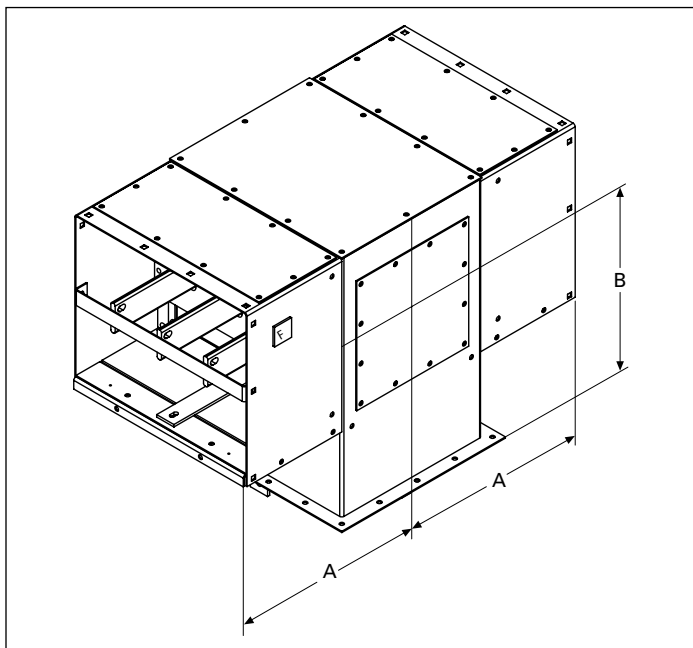

Figure 11.1-21. Downward

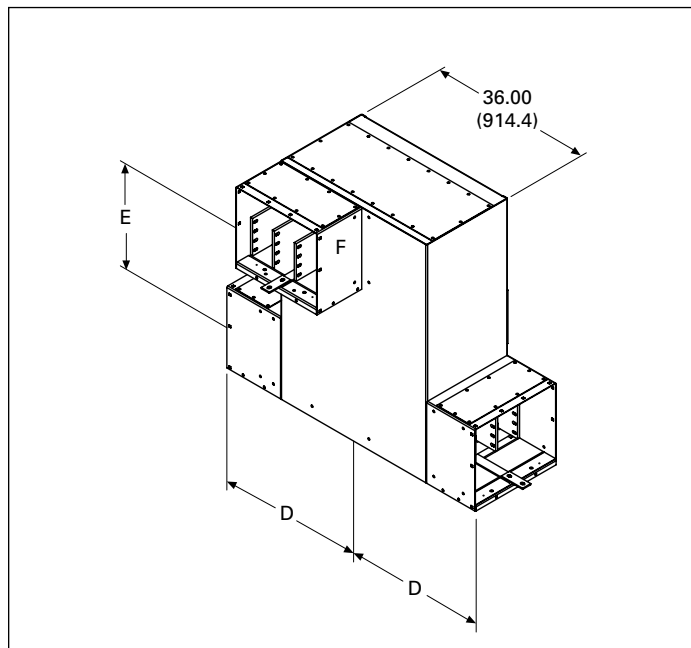

Figure 11.1-23. Forward

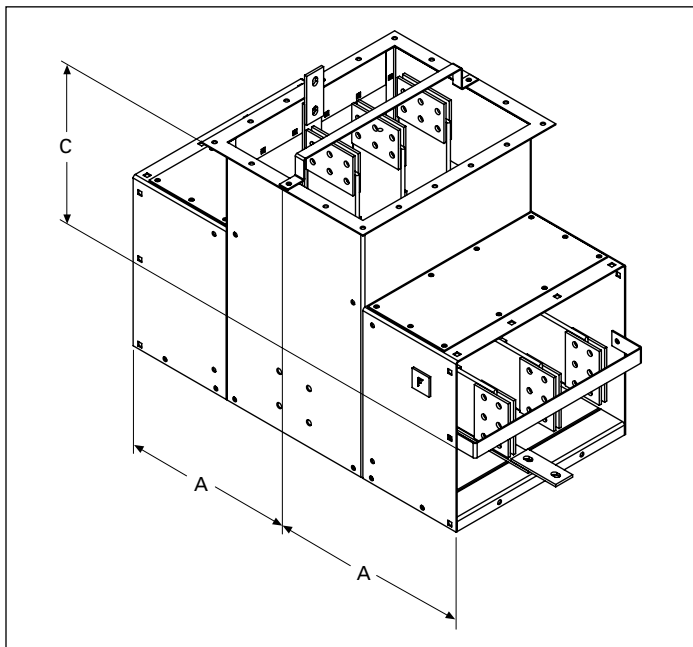

Figure 11.1-22. Upward

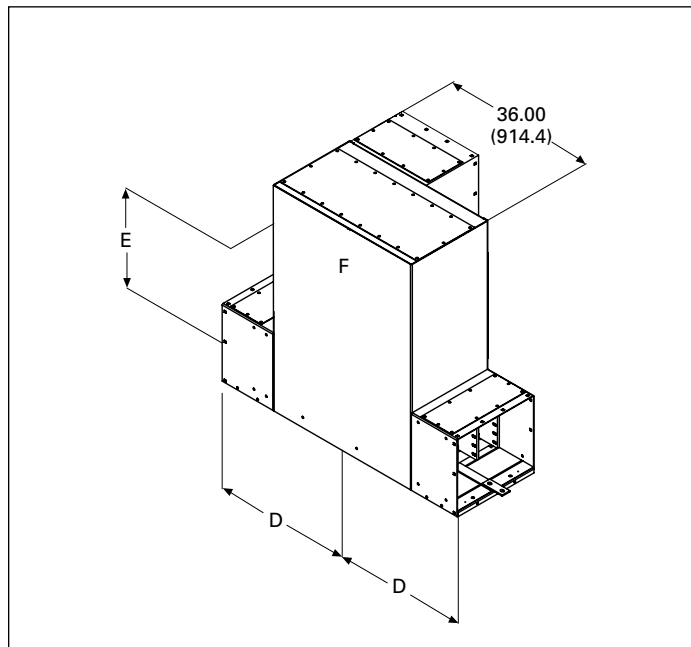

Figure 11.1-24. Rearward

Switchgear Flanges

Switchgear termination enclosures connect non-segregated phase bus to medium-voltage switchgear, medium-voltage motor control centers, and low-voltage switchgear, switchboards or motor control centers. Each enclosure is designed to coordinate with opening, drilling and bus extension detail supplied on the switchgear equipment by the switchgear supplier. Standard switchgear termination enclosures include external (turned out) flange for connections to switchgear equipment for medium-voltage applications, and internal (turned in) flange for low-voltage applications. All flanges will match switchgear roof sheet coordinations.

Table 11.1-5. Flange

Dimensions in Inches (mm)						
Amperes	Wire Type	Enclosure	50 kA		63 kA	
			A	B	A	B
1200	3	Aluminum/steel	18.25 (463.6)	18.00 (457.2)	18.25 (463.6)	18.00 (457.2)
2000	3	Aluminum/steel	18.25 (463.6)	18.00 (457.2)	18.25 (463.6)	18.00 (457.2)
3000	3	Aluminum	19.25 (489.0)	18.00 (457.2)	19.25 (489.0)	18.00 (457.2)
3000	3	Steel	19.25 (489.0)	18.00 (457.2)	—	18.00 (457.2)
3200	3	Aluminum	19.25 (489.0)	18.00 (457.2)	19.25 (489.0)	18.00 (457.2)
3200	3	Steel	19.25 (489.0)	18.00 (457.2)	—	18.00 (457.2)
4000	3	Aluminum	18.25 (463.6)	18.00 (457.2)	—	18.00 (457.2)
4000	3	Steel	18.25 (463.6)	18.00 (457.2)	—	18.00 (457.2)
5000	3	Aluminum	19.25 (489.0)	18.00 (457.2)	—	18.00 (457.2)
5000	3	Steel	19.25 (489.0)	18.00 (457.2)	—	18.00 (457.2)
6000 ①	3	Aluminum/steel	25.85 (656.6)	26.40 (670.6)	25.85 (656.6)	26.40 (670.6)
1200	4	Aluminum/steel	18.25 (463.6)	18.00 (457.2)	18.25 (463.6)	18.00 (457.2)
2000	4	Aluminum/steel	18.25 (463.6)	18.00 (457.2)	18.25 (463.6)	18.00 (457.2)
3000	4	Aluminum	19.25 (489.0)	18.00 (457.2)	19.25 (489.0)	18.00 (457.2)
3000	4	Steel	19.25 (489.0)	18.00 (457.2)	—	18.00 (457.2)
3200	4	Aluminum	19.25 (489.0)	18.00 (457.2)	19.25 (489.0)	18.00 (457.2)
3200	4	Steel	19.25 (489.0)	18.00 (457.2)	—	18.00 (457.2)
4000	4	Aluminum	18.25 (463.6)	18.00 (457.2)	—	18.00 (457.2)
4000	4	Steel	18.25 (463.6)	18.00 (457.2)	—	18.00 (457.2)
5000	4	Aluminum	19.25 (489.0)	18.00 (457.2)	—	18.00 (457.2)
5000	4	Steel	19.25 (489.0)	18.00 (457.2)	—	18.00 (457.2)
6000 ①	4	Aluminum/steel	25.85 (656.6)	26.40 (670.6)	25.85 (656.6)	26.40 (670.6)

① Switchgear flange details for 6000 A are for interleaved phase sequence (1 2 3 1 2 3 or 1 2 3 4 1 2 3 4). Please consult the factory for customized and non-interleaved phase sequence.

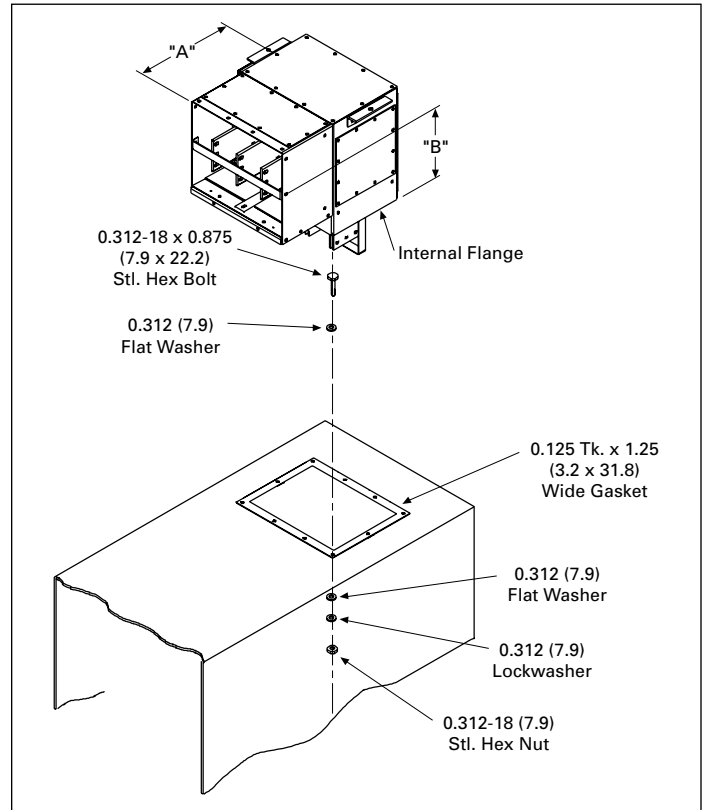

Figure 11.1-25. Low-Voltage Switchgear Flange (Internal Flange)

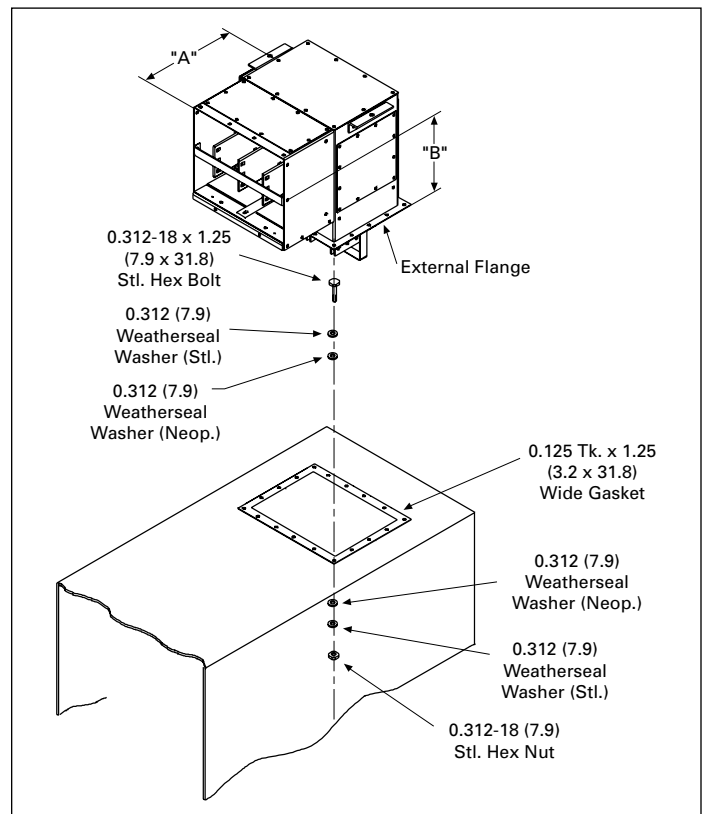

Figure 11.1-26. Medium-Voltage Switchgear Flange (External Flange)

End Cable Tap Box

End cable tap boxes (see **Figure 11.1-27**) are applied to feed a run of bus duct with cable and conduit. The enclosure is designed to accommodate specified size and number of cables per phase. Conductors are separated and provided with the required number of cable lugs per phase, and necessary space for cable termination. The enclosure is provided with removable access covers as necessary for access to power cable terminations.

Phase Transposition

Phase transposition is normally provided within the switchgear equipment. However, when required, it can be provided within the bus run system to align phasing of terminal equipment at two ends.

All dimensions are to the centerline of the non-segregated bus bar.

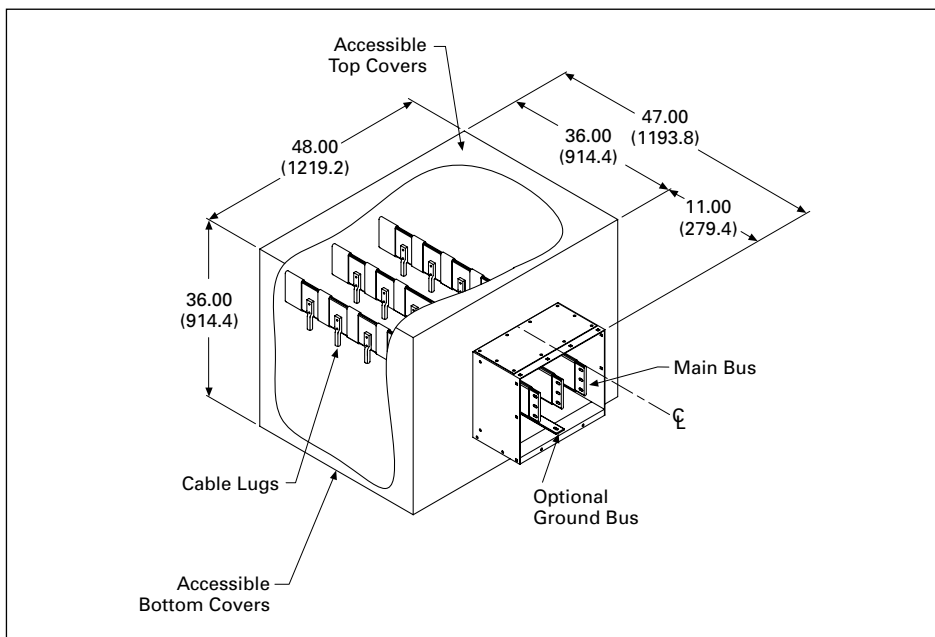

Figure 11.1-27. End Cable Tap Box

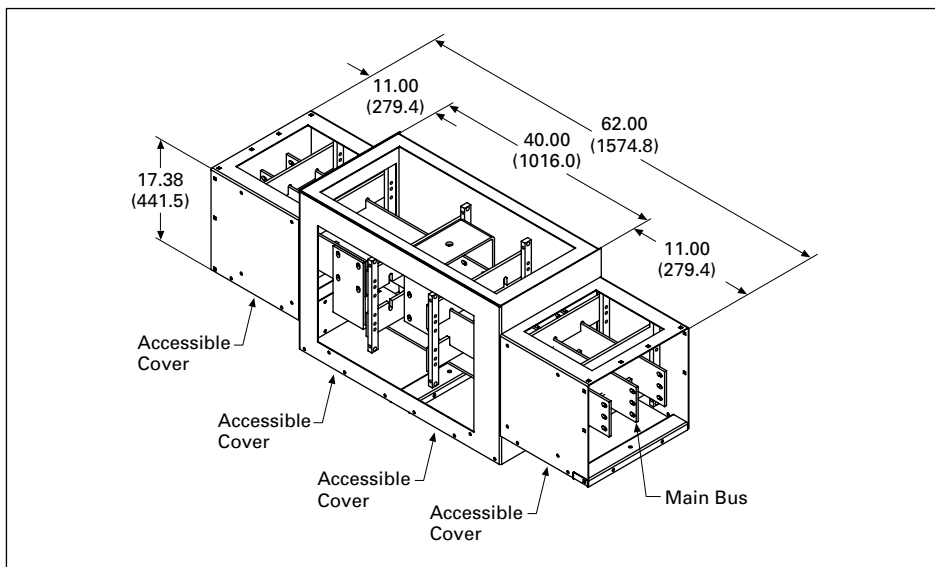

Figure 11.1-28. Phase Transposition

Fittings

Expansion Joints

An expansion joint is a special bus and housing fitting provided in long runs to accommodate thermal expansion of bus conductors with respect to steel or aluminum housing, when carrying rated continuous current. The fitting consists of two pieces of housing, each with one flange end. The flanged ends are separated by a 1.00-inch (25.4 mm) gap. A sealing ring assembly is then installed over the bolted flanges (see **Page 11.1-14**). Flexible copper braids of required ampacity connect bus conductors within the expansion fitting. An expansion joint is normally provided for every 50 feet (15 m) of straight run. However, within those 50 feet (15 m), if the bus run contains elbows or flexible termination, such as transformer throat, the expansion joint may be omitted.

The enclosure is bolted together for shipping, but the four bolts should be removed after installation.

Bushing Box Termination

This is used to connect bus duct to an outside source such as a power station or when the customer wants to connect cable that is located outdoors.

The enclosure is designed to accommodate bushing sizes of 1200–3000 A with voltages up to a maximum of 15 kV (see **Figure 11.1-30**).

The conductors are separated and provided with flex connectors on the internal portion. The enclosure will be furnished with heaters and removable access covers for maintenance.

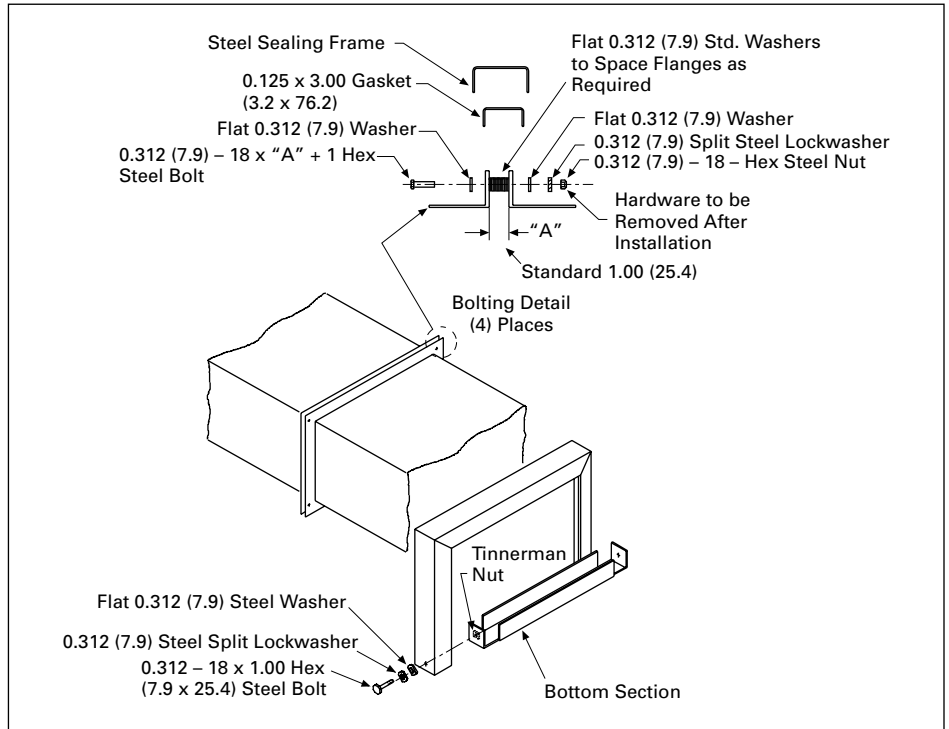

Figure 11.1-29. Expansion Joint

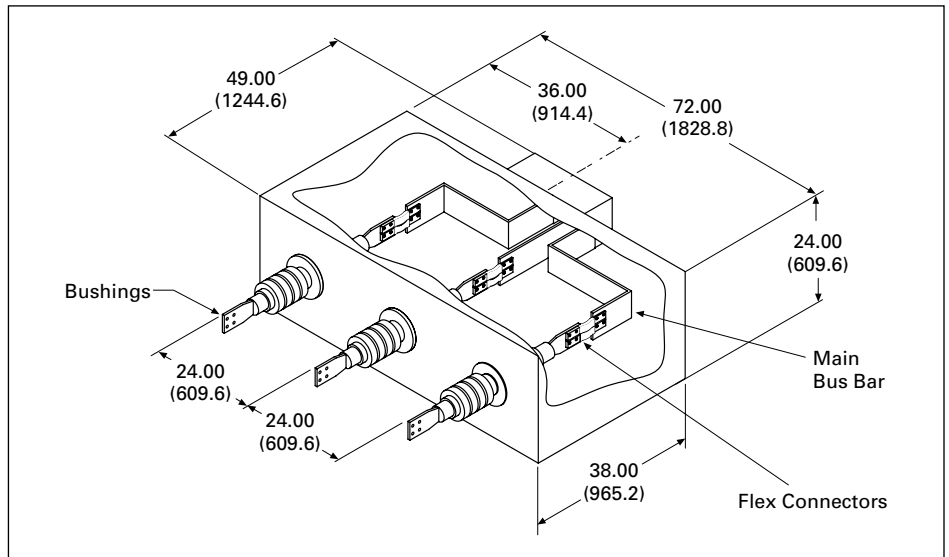

Figure 11.1-30. Bushing Box

Transformer Termination

This is a special enclosure designed to match the transformer throat. It includes a matching flange and required number of flexible copper braids for connections to transformer bushing terminal pads. The transformer termination enclosure flange is provided with or without drilling as required for a given transformer. A sealing ring kit is included for field installation around the flange connection (see **Figure 11.1-31**).

Sealing Ring

A sealing ring kit is provided for placement around enclosure-to-enclosure flange connections in an expansion fitting, and for placement around bus run flange and transformer or generator flange interface (see **Figure 11.1-32**). The sealing ring provides a weatherproof seal around such joints. The kit consists of three pieces: a U-shaped metal piece fabricated by welding together three members, a separate bottom piece and a U-shaped gasket. The sealing ring kit is installed in the field by the customer. First, the U-shaped gasket is placed upside down around flange-to-flange interface. Then the U-shaped metal piece is placed over the gasket bolted to the bottom piece to provide a weatherproof seal around the enclosure.

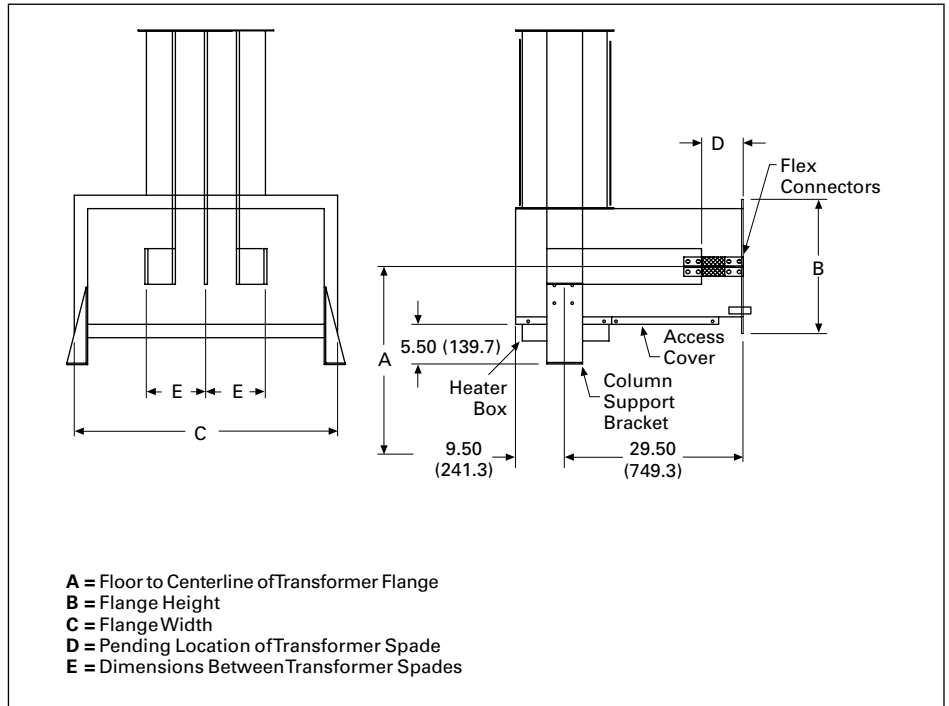

Figure 11.1-31. Transformer Termination

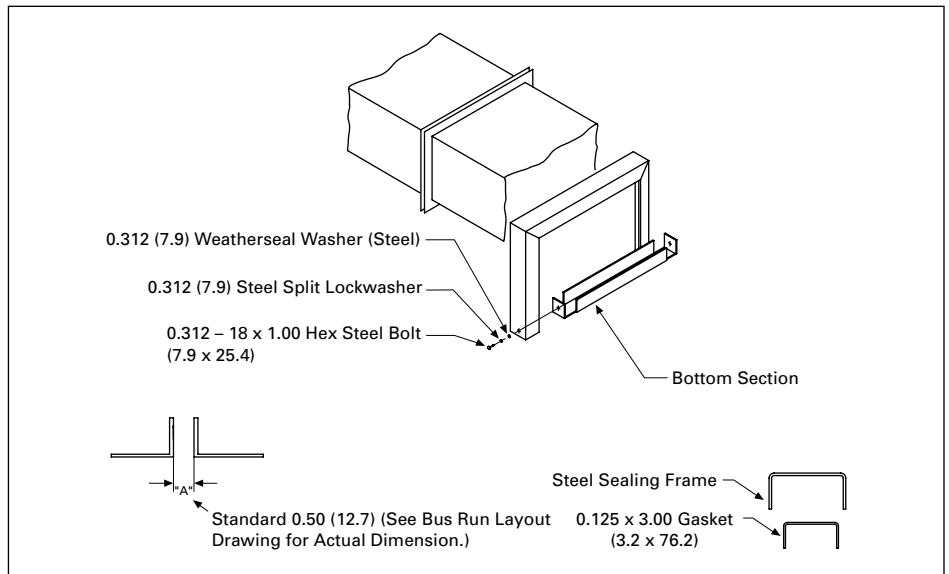

Figure 11.1-32. Sealing Ring

Vapor Barriers

Vapor barriers are two pieces of 0.75-inch (19.1 mm) thick glass polyester that are sealed with silicone sealant. The vapor barrier is used to seal construction openings and penetrations through floor slabs, walls and other building partitions and assemblies against the passage of moisture.

Fire Barriers

Fire barriers consist of desired fire-rated barrier sandwiched between two vapor barriers. Used to seal construction openings and penetrations through floor slabs, walls and other fire-rated building partitions and assemblies against the passage of flame, noxious gas, smoke and water. Restore fire-rated construction to original integrity.

Table 11.1-6. Suggested Guide for Designing Minimum Penetration Thickness for Designated Fire Ratings—in Inches (mm)

Description	Fire Rating		
	1-Hour Fire Test	2-Hour Fire Test	3-Hour Fire Test
Thickness of Dow Corning RTV Foam	4.00 (101.6)	8.00 (203.2)	12.00 (304.8)

Note: Data extracted from results of several large scale E-I 19-76 fire test of different Dow Corning silicone RTV foam penetration seal systems in both floor and wall test structures.

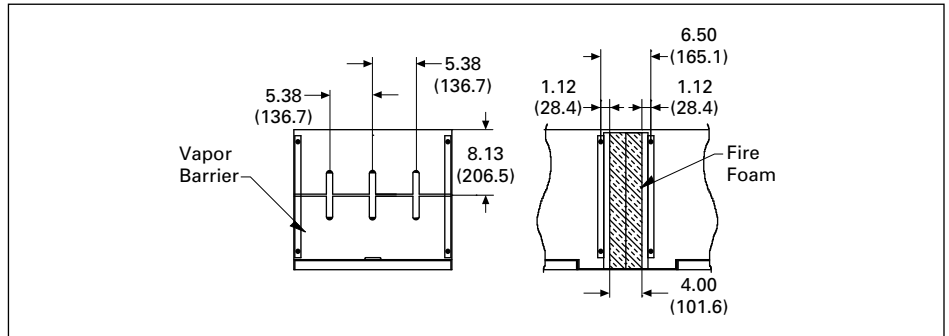

Figure 11.1-33. 1-Hour Fire Barrier

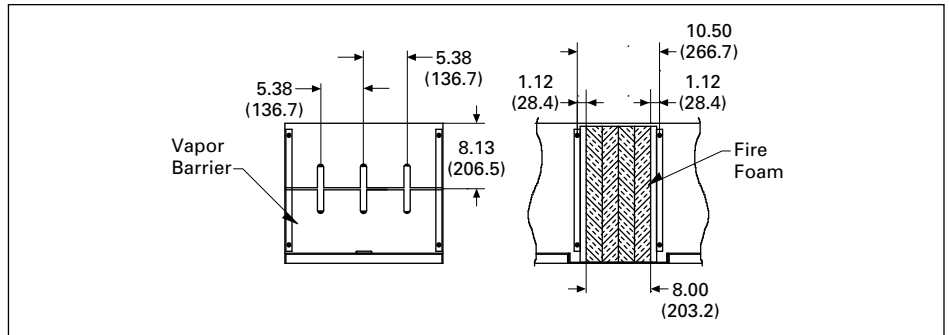

Figure 11.1-34. 2-Hour Fire Barrier

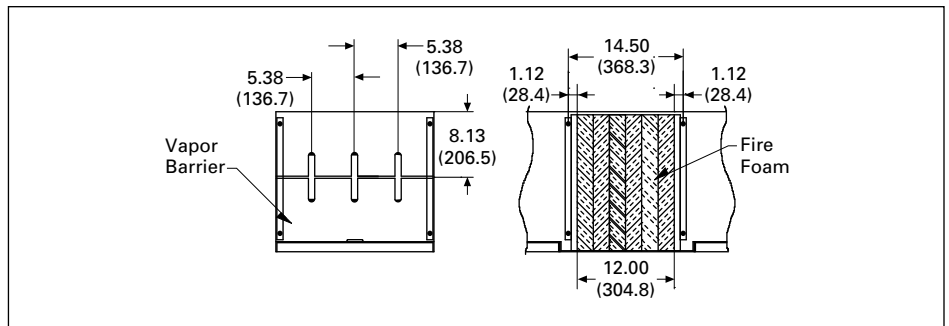

Figure 11.1-35. 3-Hour Fire Barrier

Fittings

Column Supports

Outdoor bus runs are normally supported by a single structural column with a crossbeam (typically provided by customer), which is bolted to brackets provided by Eaton on the bus housing. Special conditions may require a different design. The customer typically furnishes the columns, beams and foundation hardware for the support columns. Only the brackets are included with the bus run. Column supports should be placed every 8 to 10 feet (2.4 to 3.0 m), at transformer throats and at transitions where the run turns vertical for more than 3 feet (0.91 m).

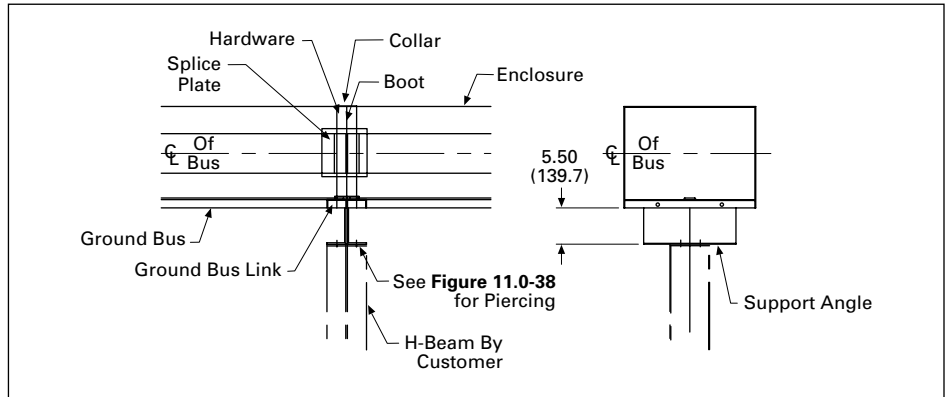

Figure 11.1-37. Column Support at Joint

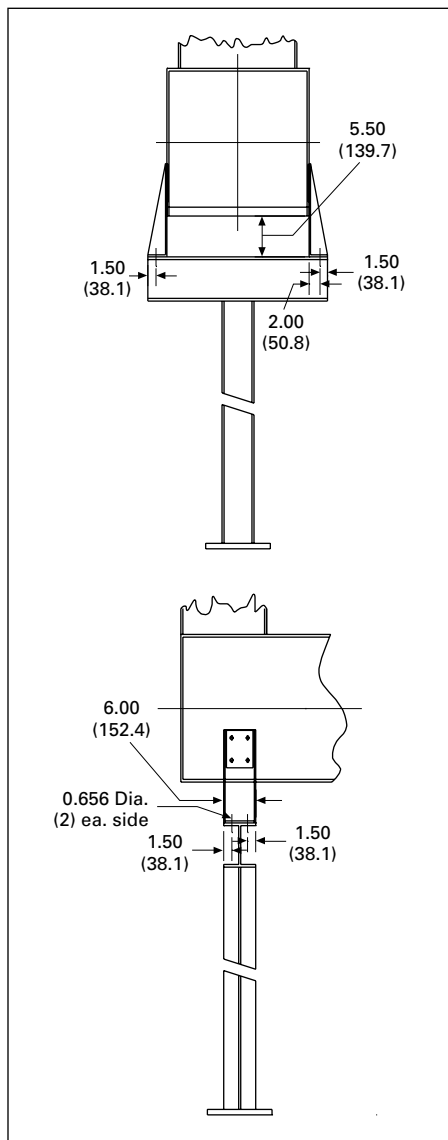

Figure 11.1-36. Column Support at Transformer

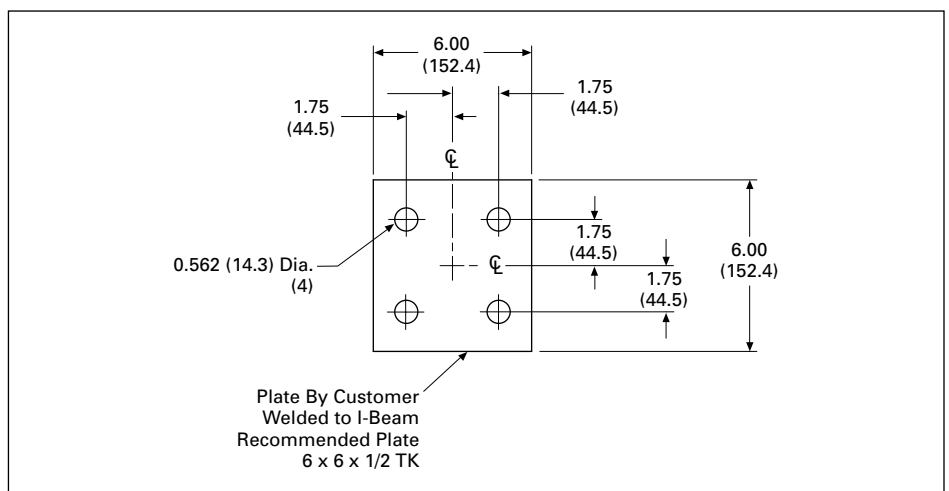

Figure 11.1-38. Beam Drilling

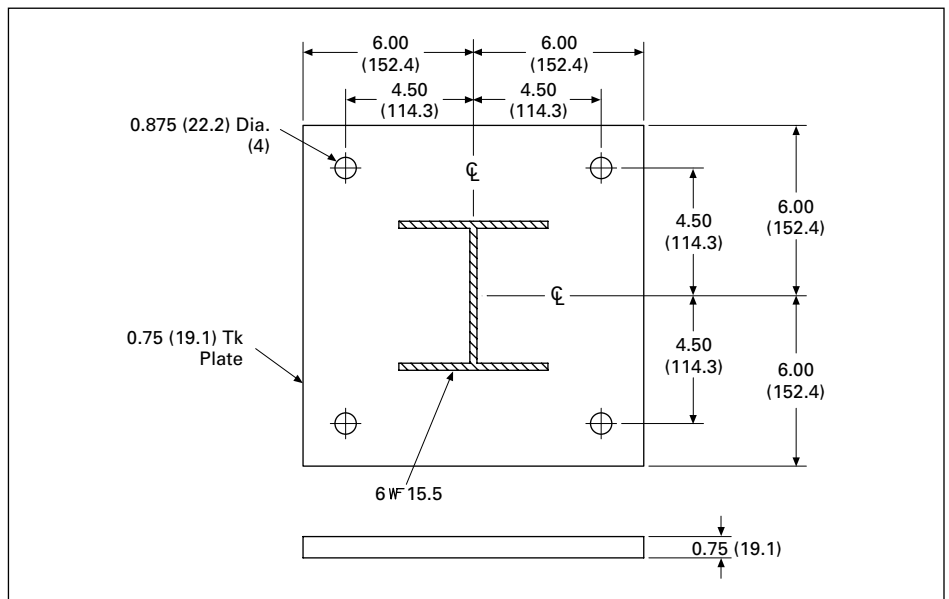

Figure 11.1-39. Base Plate Detail (If Eaton Provides Column Support)

Horizontal Hanger

The indoor bus run is attached to existing building structure through the use of 5/8-inch (15.9) diameter hanger rod assembly (see **Figure 11.1-40**). Exact placement to be determined by installer. Hanger rods and associated support material to be supplied by the customer or contractor.

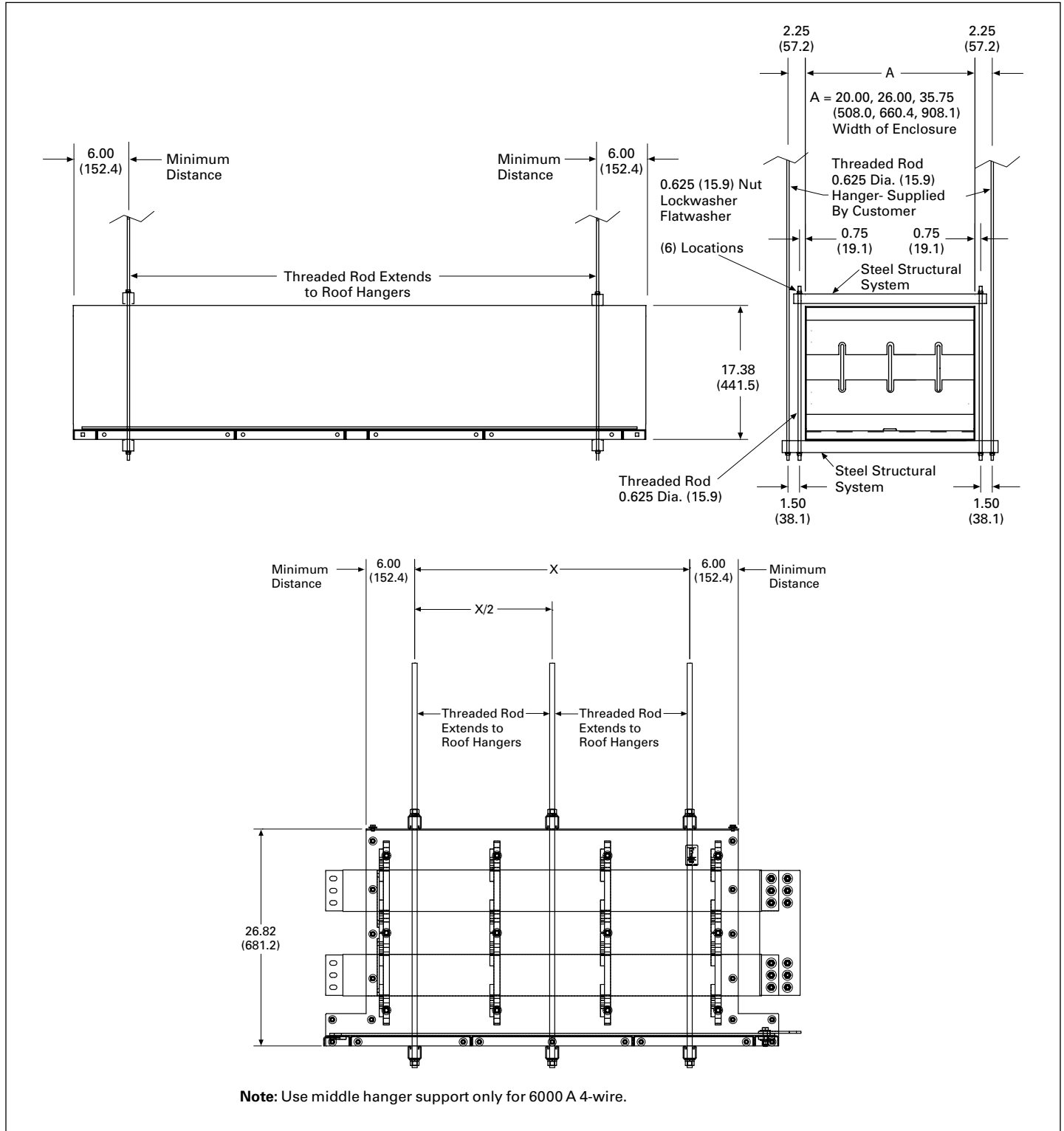

Figure 11.1-40. Horizontal Hanger Assembly

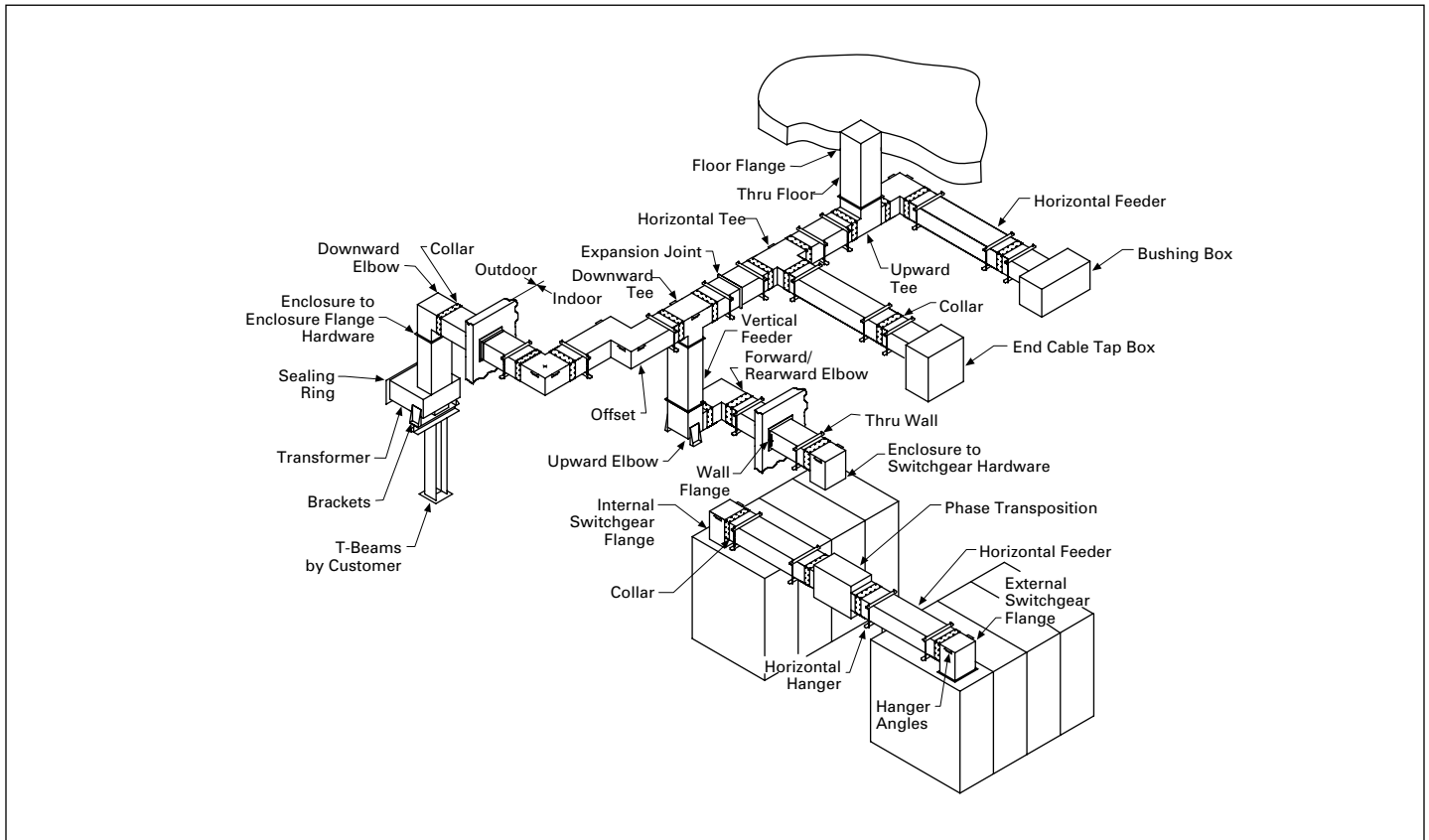

Figure 11.1-41. Typical Bus Duct Components

Wall/Floor Flange

Wall/floor flange fittings are provided when a bus run passes through a wall or floor. The wall/floor flange assembly is a sliding design. It consists of a U-shaped piece fabricated with two lips. The assembly is installed in the wall opening by the purchaser. The bus run is installed through the wall/floor flange assembly by sliding through it.

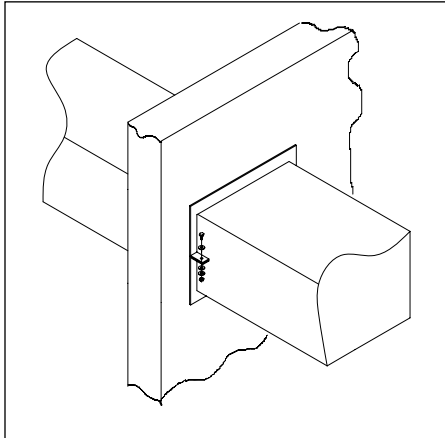

Figure 11.1-42. Wall Flange

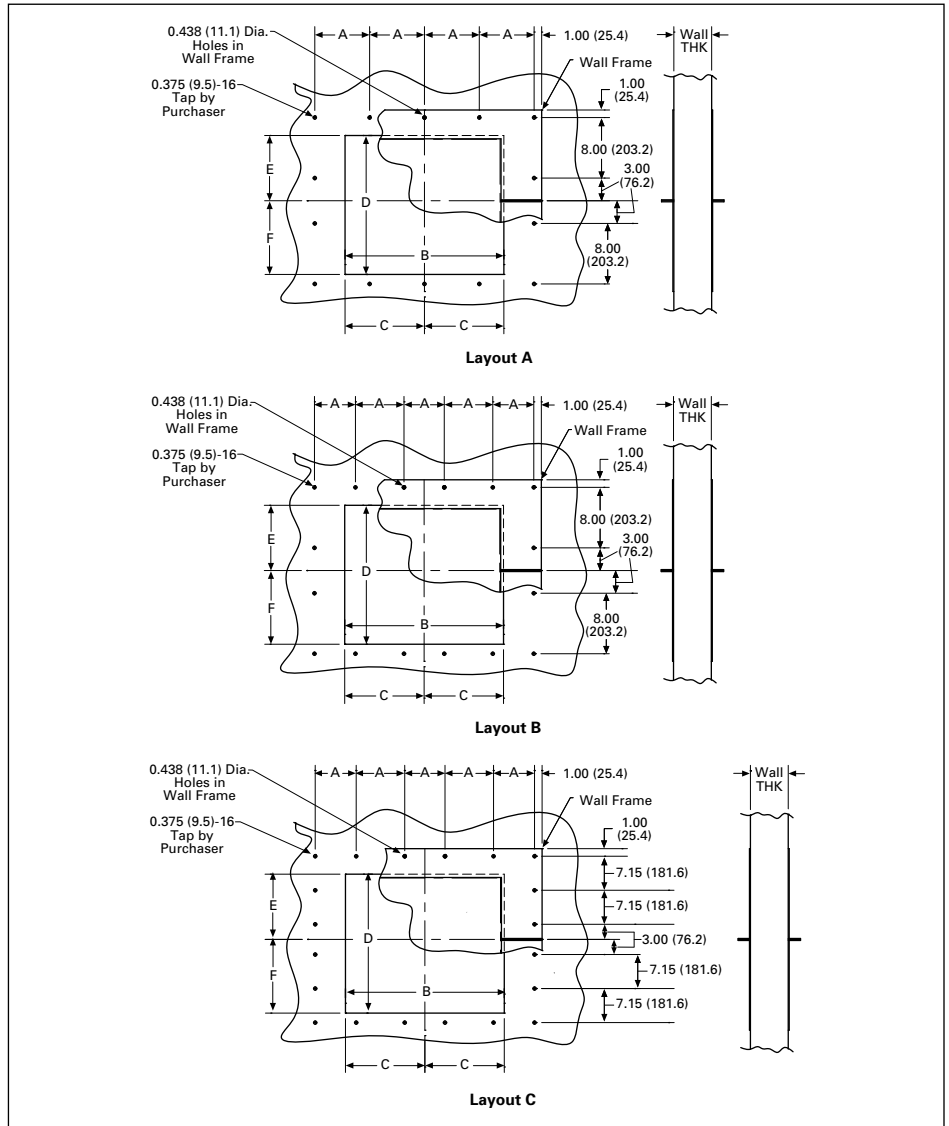

Figure 11.1-43. Wall/Floor Opening

Table 11.1-7. Wall/Floor Opening Dimensions in Inches (mm)

	Enclosure Size (Width x Height)	Layout	A	B	C	D	E	F
1	20.00 x 17.38 (508.0 x 441.5)	A	7.25 (184.2)	21.00 (533.4)	10.50 (266.7)	18.38 (466.8)	8.63 (219.2)	9.75 (247.6)
2	20.00 x 16.25 (508.0 x 412.8)		7.25 (184.2)	21.00 (533.4)	10.50 (266.7)	17.25 (438.2)	8.63 (219.2)	8.63 (219.2)
3	20.00 x 15.38 (508.0 x 390.7)		7.25 (184.2)	21.00 (533.4)	10.50 (266.7)	16.38 (416.1)	7.63 (193.8)	8.75 (222.2)
4	20.00 x 14.25 (508.0 x 362.0)		7.25 (184.2)	21.00 (533.4)	10.50 (266.7)	15.25 (387.4)	7.63 (193.8)	7.63 (193.8)
5	26.00 x 17.38 (660.4 x 441.5)		7.25 (184.2)	27.00 (685.8)	13.50 (342.9)	18.38 (466.8)	8.63 (219.2)	9.75 (247.6)
6	26.00 x 16.25 (660.4 x 412.8)		7.25 (184.2)	27.00 (685.8)	13.50 (342.9)	17.25 (438.2)	8.63 (219.2)	8.63 (219.1)
7	26.00 x 15.38 (660.4 x 390.7)		7.25 (184.2)	27.00 (685.8)	13.50 (342.9)	16.38 (416.1)	7.63 (193.8)	8.75 (222.1)
8	26.00 x 14.25 (660.4 x 362.0)		7.25 (184.2)	27.00 (685.8)	13.50 (342.9)	15.25 (387.4)	7.63 (193.8)	7.63 (193.8)
9	35.75 x 17.38 (908.1 x 441.5)	B	8.00 (203.2)	36.75 (933.5)	18.38 (466.9)	18.38 (466.8)	8.63 (219.2)	9.75 (247.6)
10	35.75 x 16.25 (908.1 x 412.8)		8.00 (203.2)	36.75 (933.5)	18.38 (466.9)	17.25 (438.2)	8.63 (219.2)	8.63 (219.2)
11	35.75 x 15.38 (908.1 x 390.7)		8.00 (203.2)	36.75 (933.5)	18.38 (466.9)	16.38 (416.1)	7.63 (193.8)	8.75 (222.2)
12	35.75 x 14.25 (908.1 x 362.0)		8.00 (203.2)	36.75 (933.5)	18.38 (466.9)	15.25 (387.4)	7.63 (193.8)	7.63 (193.8)
13	35.75 x 26.82 (908.1 x 681.2)	C	8.00 (203.2)	36.75 (933.5)	18.38 (466.9)	27.82 (706.6)	13.91 (353.3)	13.91 (353.3)
14	35.75 x 25.69 (908.1 x 652.5)		8.00 (203.2)	36.75 (933.5)	18.38 (466.9)	26.69 (677.9)	13.35 (339.1)	13.35 (339.1)

Space Heaters

Space heaters are provided on outdoor bus duct runs for use with customer-supplied 120 or 240Vac power supply at 250 watts for both. Consult the factory for additional heater ratings. Heaters come pre-wired using #14 shielded pair cable with a terminal block ready to accept customer-supplied power. The heaters are continuously energized or may be thermostat controlled. There is one heater provided every 8 ft (2.4 m) as standard.

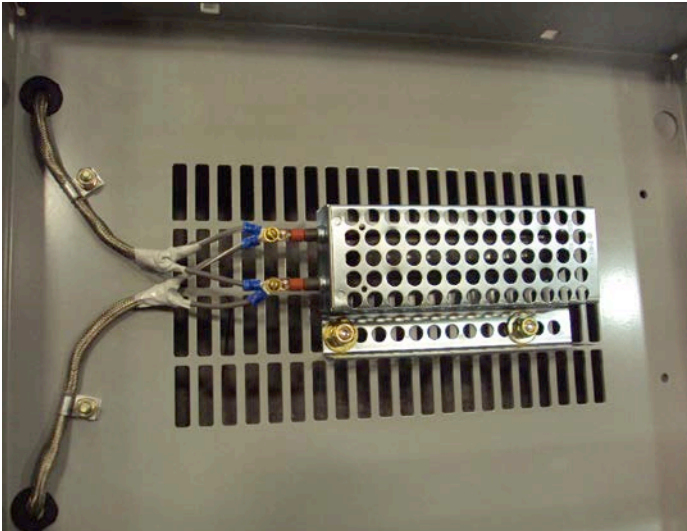

Installation Diagrams

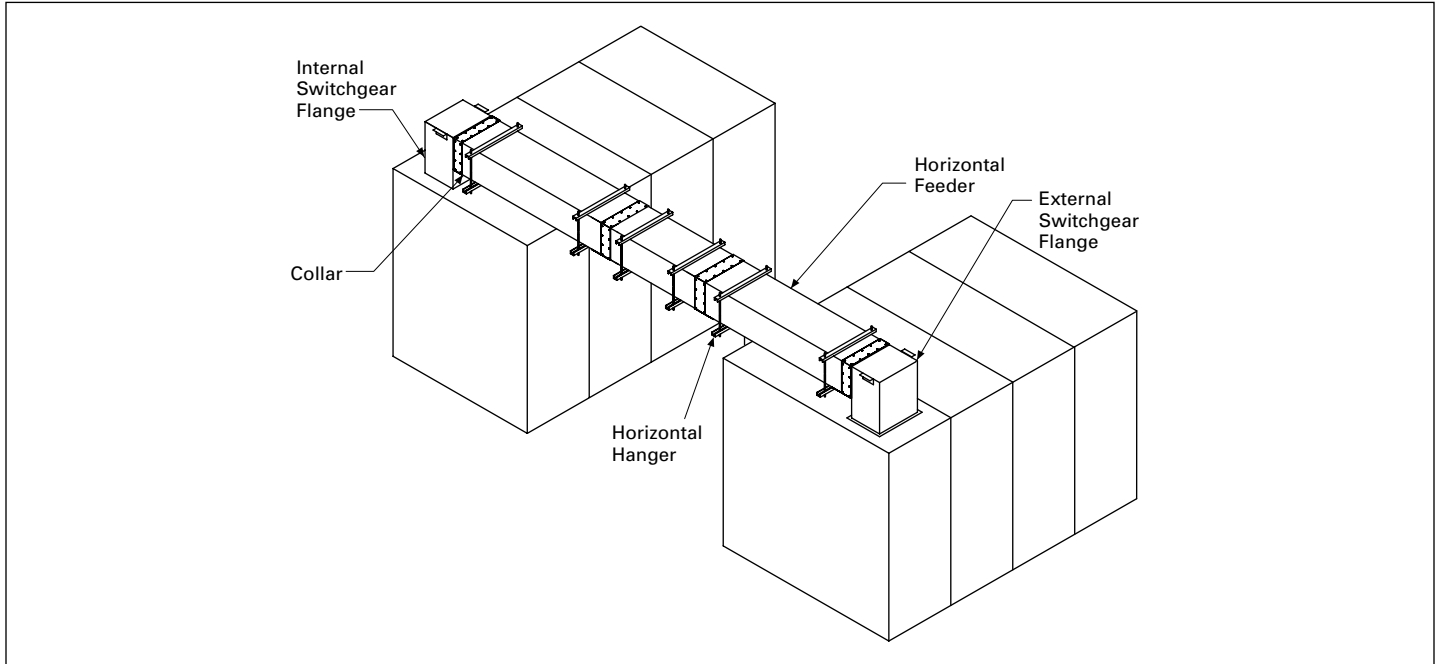

Figure 11.1-46. Typical Bus Run (Switchgear-to-Switchgear)

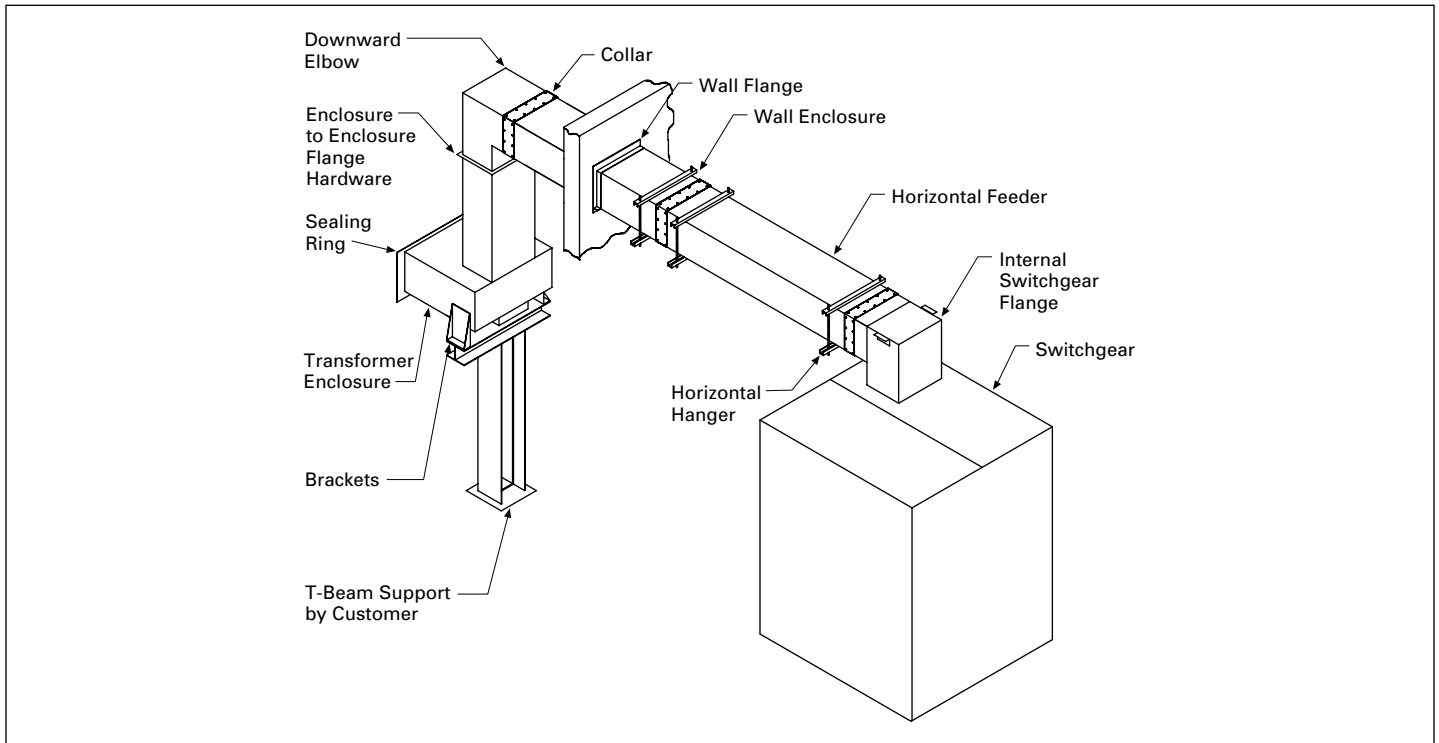

Figure 11.1-47. Typical Bus Run (Switchgear-to-Transformer)

Layout

Field Fit

A field fit section of bus is typically an elbow or a short length of feeder that is intentionally left out of a run for later shipment. It is most often a mutually agreed upon section between the customer and the plant. The purpose of the program is to effectively manage the dimensional uncertainties that may be involved in a bus layout.

The example shown in **Figure 11.1-48** identifies the field fit piece as a straight length.

Upon release of the order, this item is kept on hold for field measurement.

The contractor installs the bus duct and is then able to obtain an exact dimension for the final field fit piece. The measurement should be made per individual measuring instructions provided on the customized final field fit forms that are provided with the customer drawing package. See **Figure 11.1-49** on the following page for an example of the final field fit form.

Using the email address shown on the form, the contractor can email the dimensions of the piece directly to the factory on the Final Field Fit Release form, which is packed with the original shipment.

The field fit section will ship in an expedited manner based on type of piece and quantity of field fits released. This program has been successful for many years and it provides assurance of an exact fit the first time. It allows bus duct to be released when certain dimensions are not yet determined. It also eliminates the costly delays that can occur when sections have to be remade and shipped due to last minute job site changes. In turn, this allows installations to begin early and projects can be completed on time.

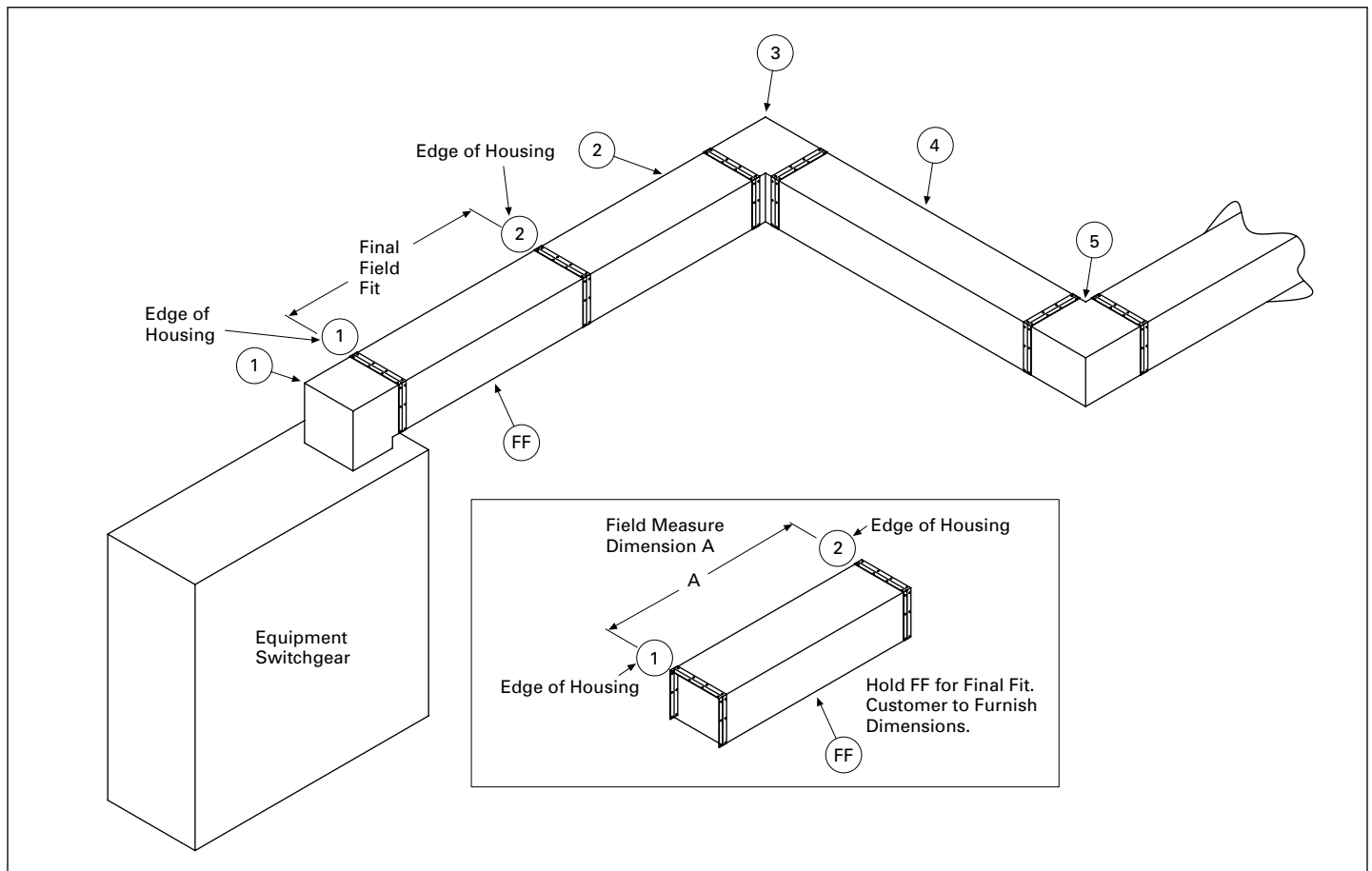

Figure 11.1-48. Final Field Fit

Final Field Fit Program

Item Release!

Email Directly to Greenwood busway factory.

Ref. Drawing:

G.O. #:

Item #:

Phone #: 864-942-6310

Email Address: buswayfieldfit@eaton.com

Customer to provide dimensions indicated by letters on field fit section of busway. In order to help expedite your release please include the GO# and Item# listed above on this sheet in the subject line of your email message.

A Dimension = _____ (20" min.)

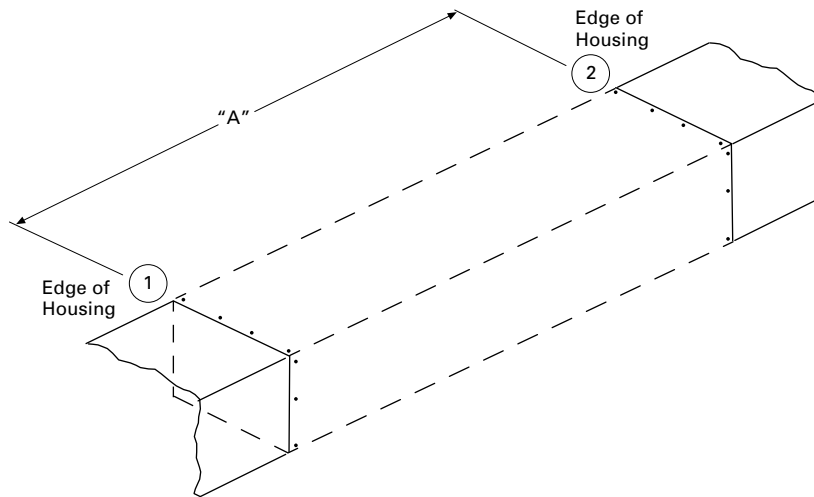

Name: _____

Company: _____

Phone #: _____ Email: _____

Date: _____

List other field fit items released at this time: _____

Requested Ship Date: _____

Lead times shown below are in working days from receipt of complete information.

	Poly	Porcelain	Epoxy
1-5 Straight Pieces	10-15 days	15-20 days	15-20 days
6-10 Straight Pieces	15-20 days	15-20 days	15-20 days
More	Consult Factory	Consult Factory	Consult Factory

Note: Number of pieces is per project, not per run, and could be included on multiple order numbers.

Figure 11.1-49. Final Field Fit Form

Electrical Data

Table 11.1-8. Available Non-Segregated Bus Ratings per ANSI/IEEE Standard C37.23 ①

Rated Maximum Voltage kV rms	Rated Power Frequency Hz	Power Frequency Withstand 1 min. Dry, kV rms	Impulse Withstand (1.2 x 50 microsec) kV Peak	Rated Continuous Current Amperes	Rated Short-Time Short-Circuit Withstand Current (kA rms Symmetrical)		Rated Momentary Short-Circuit Withstand Current	
					2 Sec.	1 Sec. ②	10 Cycle	
							kA Peak	kA rms Asym.
0.635	60	2.2	10	1200 2000 3000 3200 4000 5000	50	70.7	130 ③	78 ③
0.635	60	2.2	60	6000	50	70.7 ③	130 ③	78 ③
0.635	60	2.2	10	1200 2000 3000 3200 4000 5000	63	89	170	101
0.635	60	2.2	60	6000	63	89	170 ④	101 ④
4.76	60	19	60	1200 2000 3000 3200 4000 5000 6000	50	—	130	78
4.76	60	19	60	1200 2000 3000 3200 4000 5000 6000	63	—	170	101
15	60	36	95	1200 2000 3000 3200 4000 5000 6000	50	—	130	78
15	60	36	95	1200 2000 3000 3200 4000 5000 6000	63	—	170	101
27	60	60	125	1200 2000	40	—	108	64
38	60	80	150	1200 2000 3000	40	—	108	64

① Refer to Table 11.1-9, Table 11.1-10 and Table 11.1-11 for available CSA and UL® listings.

② This is a value calculated from 2-second short-circuit withstand current rating based on relationship $I^2t = \text{constant}$.

③ For 635V applications, 4-cycle momentary current withstand rating up to 158 kA peak (98.9 kA rms asymmetrical) is also available.

④ For 6000 A applications, 10 cycle momentary current withstand rating up to 206 kA peak (123 kA rms asymmetrical) is also available.

Physical Data

Dimensions

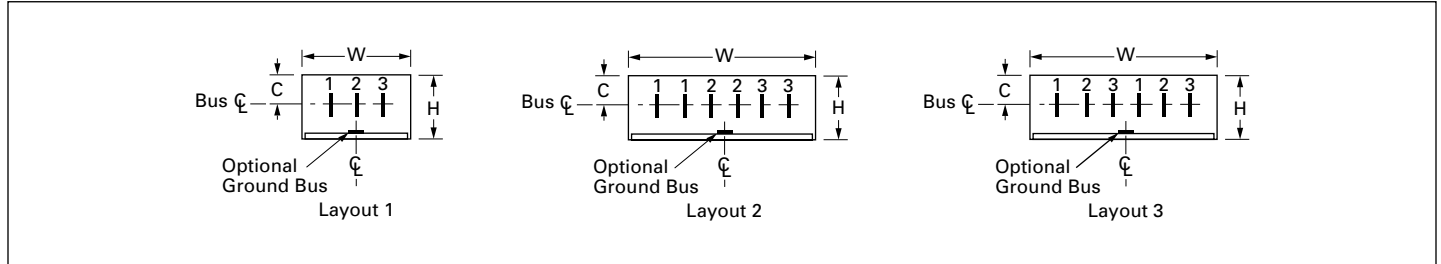

Figure 11.1-50. Medium-Voltage Non-Segregated Phase Bus—Standard Configurations

Table 11.1-9. Bus Duct Rated 50 kA rms Symmetrical 2 Seconds

Wire	Voltage kV ①	Ampere Rating	Layout No.	Width	Height	Conductor Centerline	Conductor Size	Phase-Phase Conductor Spacing	Bracing Supports ②	Optional Ground Bus	Average Weight Per Foot ③	Standards Listing
Aluminum Enclosures												
3	0.635/5/15	1200	1	20.00	17.38	8.13	(1) 0.50 x 3	5.38	Glass polyester	0.25 x 2.00	38	CSA
	0.635/5/15	2000	1	20.00	17.38	8.13	(1) 0.38 x 6	5.38	Glass polyester	0.25 x 2.00	47	CSA
	0.635/5/15	3000	1	20.00	17.38	8.13	(1) 0.50 x 8	5.38	Glass polyester	0.25 x 2.00	68	CSA
3	0.635/5/15	3200	1	20.00	17.38	8.13	(1) 0.50 x 8	5.38	Glass polyester	0.25 x 2.00	68	CSA
	0.635/5/15	4000	2	35.75	17.38	8.13	(2) 0.50 x 6	5.38	Glass polyester	0.25 x 2.00	101	CSA
	0.635/5/15	5000	2	35.75	17.38	8.13	(2) 0.50 x 8	5.38	Glass polyester	0.25 x 2.00	125	CSA
	0.635/5/15	6000	12	35.75	26.82	7.63	(4) 0.50 x 5	5.38	Glass polyester	0.25 x 2.00	160	CSA
4	0.635/5/15	1200	4	26.00	17.38	8.13	(1) 0.50 x 3	5.38	Glass polyester	0.25 x 2.00	48	CSA
	0.635/5/15	2000	4	26.00	17.38	8.13	(1) 0.38 x 6	5.38	Glass polyester	0.25 x 2.00	60	CSA
	0.635/5/15	3000	4	26.00	17.38	8.13	(1) 0.50 x 8	5.38	Glass polyester	0.25 x 2.00	88	CSA
4	0.635/5/15	3200	4	26.00	17.38	8.13	(1) 0.50 x 8	5.38	Glass polyester	0.25 x 2.00	88	CSA
	0.635	4000	5	35.75	17.38	8.13	(2) 0.50 x 6	4.00	Glass polyester	0.25 x 2.00	127	CSA
	0.635	5000	5	35.75	17.38	8.13	(2) 0.50 x 8	4.00	Glass polyester	0.25 x 2.00	134	CSA
	0.635	6000	13	35.75	26.82	7.63	(4) 0.50 x 5	4.00	Glass polyester	0.25 x 2.00	180	CSA
Steel Enclosures (Steel, Stainless Steel and Galvanized Steel)												
3	0.635/5/15	1200	1	20.00	17.38	8.13	(1) 0.50 x 3	5.38	Glass polyester	0.25 x 2.00	58	CSA
	0.635/5/15	2000	1	20.00	17.38	8.13	(1) 0.38 x 6	5.38	Glass polyester	0.25 x 2.00	67	CSA
	0.635/5/15	3000	2	35.75	17.38	8.13	(2) 0.50 x 4	5.38	Glass polyester	0.25 x 2.00	106	—
3	0.635/5/15	3200	2	35.75	17.38	8.13	(2) 0.50 x 4	5.38	Glass polyester	0.25 x 2.00	106	—
	0.635/5/15	4000	2	35.75	17.38	8.13	(2) 0.50 x 8	5.38	Glass polyester	0.25 x 2.00	154	—
	0.635/5/15	5000	3	35.75	17.38	8.13	(2) 0.50 x 8	5.38	Glass polyester	0.25 x 2.00	154	—
	0.635/5/15	6000	12	35.75	26.82	7.63	(4) 0.50 x 5	5.38	Glass polyester	0.25 x 2.00	175	CSA
4	0.635/5/15	1200	4	26.00	17.38	8.13	(1) 0.50 x 3	5.38	Glass polyester	0.25 x 2.00	72	CSA
	0.635/5/15	2000	4	26.00	17.38	8.13	(1) 0.38 x 6	5.38	Glass polyester	0.25 x 2.00	84	CSA
	0.635	3000	5	35.75	17.38	8.13	(2) 0.50 x 4	4.00	Glass polyester	0.25 x 2.00	124	—
4	0.635	3200	5	35.75	17.38	8.13	(2) 0.50 x 4	4.00	Glass polyester	0.25 x 2.00	124	—
	0.635	4000	5	35.75	17.38	8.13	(2) 0.50 x 8	4.00	Glass polyester	0.25 x 2.00	188	—
	0.635	5000	5	35.75	17.38	8.13	(2) 0.50 x 8	4.00	Glass polyester	0.25 x 2.00	188	—
	0.635	6000	13	35.75	26.82	7.63	(4) 0.50 x 5	4.00	Glass polyester	0.25 x 2.00	200	CSA

① All phase conductors above 635V are fully insulated with epoxy insulation for the rated maximum voltage. Epoxy insulation is available at 600V as an option.

② Optional poly/porcelain or poly/epoxy bracing supports are available. Consult factory.

③ Add 3 lb up to 5000 A and 6 lb for 6000 A to the weights shown when using poly/porcelain or poly/epoxy support bracing.

Note: For dimensions in mm, multiply inches by 25.4.

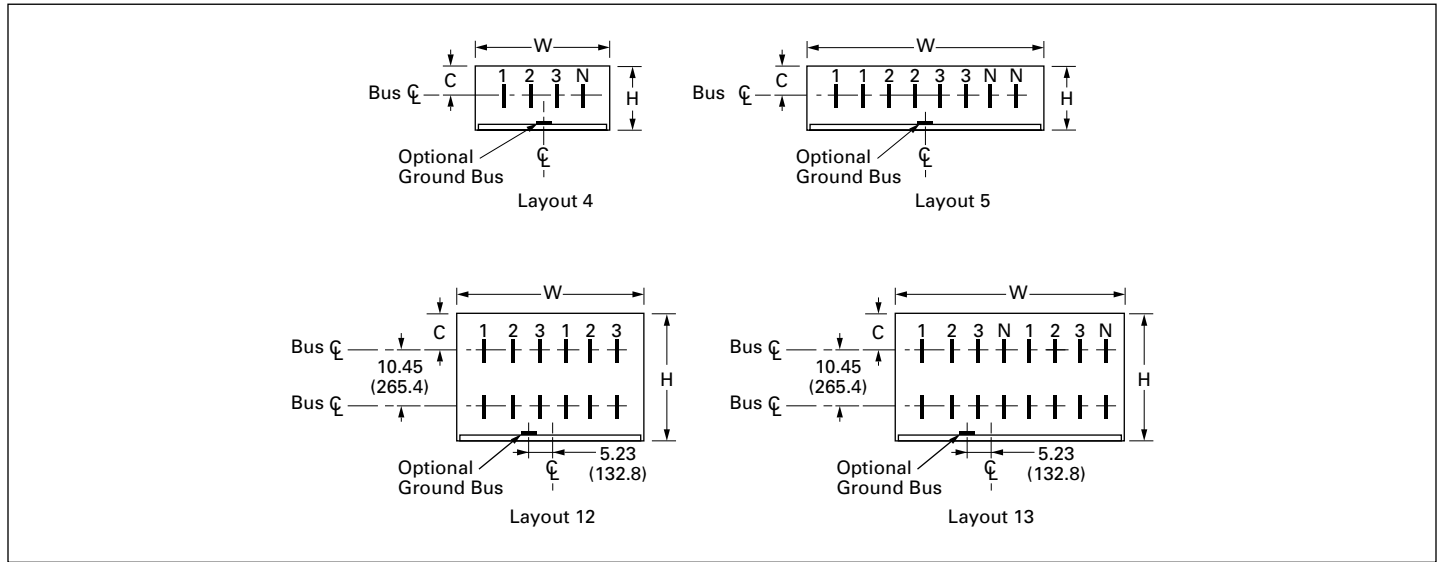

Figure 11.1-51. Medium-Voltage Non-Segregated Phase Bus—Standard Configurations

Table 11.1-10. Bus Duct Rated 63 kA rms Symmetrical 2 Seconds

Wire	Voltage kV ^①	Ampere Rating	Layout No.	Width	Height	Conductor Centerline	Conductor Size	Phase-Phase Conductor Spacing	Bracing Supports ^②	Ground Bus	Average Weight Per Foot ^③	Standards Listing
Aluminum Enclosures												
3	0.635/5/15	1200	1	20.00	17.38	8.13	(1) 0.38 x 6	5.38	Glass polyester	0.25 x 3	48	CSA
	0.635/5/15	2000	1	20.00	17.38	8.13	(1) 0.38 x 6	5.38	Glass polyester	0.25 x 3	48	CSA
	0.635/5/15	3000	1	20.00	17.38	8.13	(1) 0.50 x 8	5.38	Glass polyester	0.25 x 3	78	CSA
3	0.635/5/15	3200	1	20.00	17.38	8.13	(1) 0.50 x 8	5.38	Glass polyester	0.25 x 3	78	CSA
	0.635/5/15	4000	2	35.75	17.38	8.13	(2) 0.50 x 6	5.38	Glass polyester	0.25 x 3	105	CSA
	0.635/5/15	5000	2	35.75	17.38	8.13	(2) 0.50 x 8	5.38	Glass polyester	0.25 x 3	125	CSA
	0.635/5/15	6000	12	35.75	26.82	7.63	(4) 0.50 x 5	5.38	Glass polyester	0.25 x 3	170	CSA
4	0.635/5/15	1200	4	26.00	17.38	8.13	(1) 0.38 x 6	5.38	Glass polyester	0.25 x 3	61	CSA
	0.635/5/15	2000	4	26.00	17.38	8.13	(1) 0.38 x 6	5.38	Glass polyester	0.25 x 3	61	CSA
	0.635/5/15	3000	4	26.00	17.38	8.13	(1) 0.50 x 8	5.38	Glass polyester	0.25 x 3	101	CSA
4	0.635/5/15	3200	4	26.00	17.38	8.13	(1) 0.50 x 8	5.38	Glass polyester	0.25 x 3	101	CSA
	0.635	4000	5	35.75	17.38	8.13	(2) 0.50 x 6	4.00	Glass polyester	0.25 x 3	128	CSA
	0.635	5000	5	35.75	17.38	8.13	(2) 0.50 x 8	4.00	Glass polyester	0.25 x 3	137	CSA
	0.635	6000	13	35.75	26.82	7.63	(4) 0.50 x 5	4.00	Glass polyester	0.25 x 3	190	CSA
Steel Enclosures (Steel, Stainless Steel and Galvanized Steel)												
3	0.635/5/15	1200	1	20.00	17.38	8.13	(1) 0.38 x 6	5.38	Glass polyester	0.25 x 3	68	CSA
	0.635/5/15	2000	1	20.00	17.38	8.13	(1) 0.38 x 6	5.38	Glass polyester	0.25 x 3	68	CSA
	0.635/5/15	3000	2	35.75	17.38	8.13	(2) 0.50 x 4	5.38	Glass polyester	0.25 x 3	107	—
3	0.635/5/15	3200	2	35.75	17.38	8.13	(2) 0.50 x 4	5.38	Glass polyester	0.25 x 3	107	—
	0.635/5/15	4000	2	35.75	17.38	8.13	(2) 0.50 x 8	5.38	Glass polyester	0.25 x 3	155	—
	0.635/5/15	5000	3	35.75	17.38	8.13	(2) 0.50 x 8	5.38	Glass polyester	0.25 x 3	155	—
	0.635/5/15	6000	12	35.75	26.82	7.63	(4) 0.50 x 5	5.38	Glass polyester	0.25 x 3	185	CSA
4	0.635/5/15	1200	4	26.00	17.38	8.13	(1) 0.38 x 6	5.38	Glass polyester	0.25 x 3	85	CSA
	0.635/5/15	2000	4	26.00	17.38	8.13	(1) 0.38 x 6	5.38	Glass polyester	0.25 x 3	85	CSA
	0.635	3000	5	35.75	17.38	8.13	(2) 0.50 x 4	4.00	Glass polyester	0.25 x 3	125	—
4	0.635	3200	5	35.75	17.38	8.13	(2) 0.50 x 4	4.00	Glass polyester	0.25 x 3	125	—
	0.635	4000	5	35.75	17.38	8.13	(2) 0.50 x 8	4.00	Glass polyester	0.25 x 3	188	—
	0.635	5000	5	35.75	17.38	8.13	(2) 0.50 x 8	4.00	Glass polyester	0.25 x 3	188	—
	0.635	6000	13	35.75	26.82	7.63	(4) 0.50 x 5	4.00	Glass polyester	0.25 x 3	210	CSA

① All phase conductors above 635 V are fully insulated with epoxy insulation for the rated maximum voltage. Epoxy insulation is available at 600 V as an option.

② Optional poly/porcelain or poly/epoxy bracing supports are available. Consult factory.

③ Add 3 lb up to 5000 A and 6 lb for 6000 A to the weights shown when using poly/porcelain or poly/epoxy support bracing.

Note: For dimensions in mm, multiply inches by 25.4.

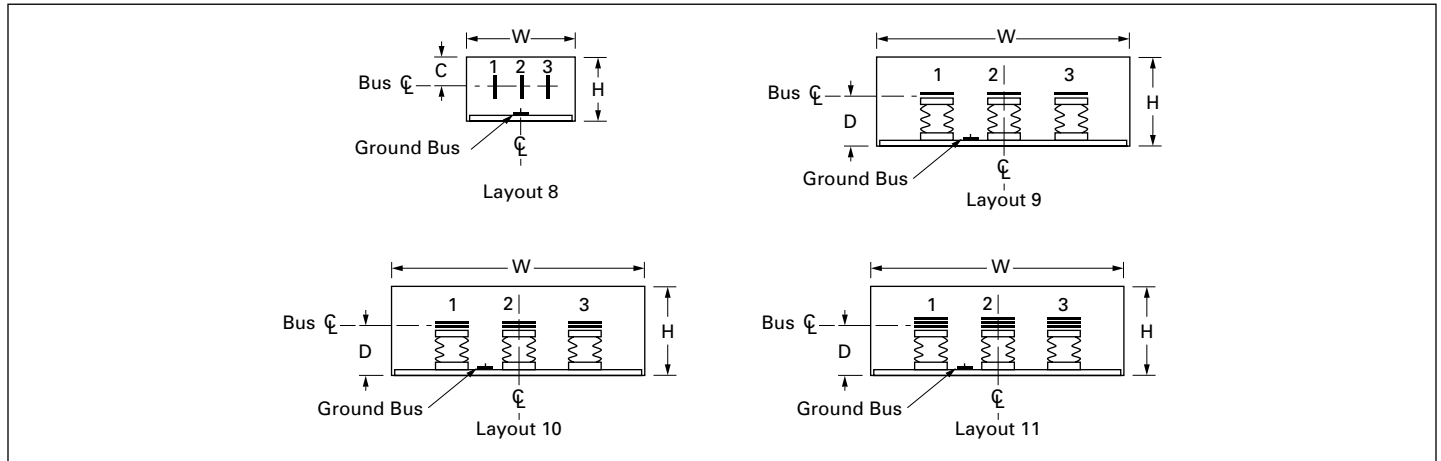

Figure 11.1-52. Dimensional Data for 27 kV/38 kV Non-Segregated Phase Bus—Standard Configurations

Table 11.1-11. Dimensional Data for 27 kV Bus Rated up to 108 kA Peak Momentary, 40 kA rms Symmetrical 2 Second

Wire Type	Rated Maximum Voltage kV ①	Rated Cont. Current Amperes	Layout No.	Enclosure Material		Enclosure Size (Inches)			# of Bars Ph and Size, Cu (Inches) ①	Ph-Ph Bus Spacing (Inches)	Insulating Supports			Optional Ground Bus, Cu (Inches)	Approx. Average Weight per Ft (Lb) ③	Listing	
				Standard	Optional	W	H	C			Standard	Optional ②	CSA			UL	
3	27	1200	8	Aluminum	—	30.00	21.13	10.00	(1) 0.25 x 4	7.00	④	⑤	⑥	0.25 x 2.00	37	Yes	No
	27	2000	8	Aluminum	—	30.00	21.13	10.00	(1) 0.50 x 4	7.00	④	⑤	⑥	0.25 x 2.00	49	Yes	No
3	27	1200	8	—	Steel	30.00	21.13	10.00	(1) 0.25 x 4	7.00	④	⑤	⑥	0.25 x 2.00	66	Yes	No
	27	2000	8	—	Steel	30.00	21.13	10.00	(1) 0.50 x 4	7.00	④	⑤	⑥	0.25 x 2.00	78	Yes	No

① All bus bars for applications above 600V are fully insulated with fluidized epoxy coating for the rated maximum voltage.

② Check with Eaton for availability.

③ Add 3 lb to the weights shown when using poly/porcelain or epoxy insulating supports in place of glass polyester.

④ Glass polyester.

⑤ Polyester/porcelain.

⑥ Epoxy.

Note: For dimensions in mm, multiply inches by 25.4.

Table 11.1-12. Dimensional Data for 38 kV Bus Rated up to 104 kA Peak Momentary, 40 kA rms Symmetrical 2 Second

Wire Type	Rated Maximum Voltage kV ⑦	Rated Cont. Current Amperes	Layout No.	Enclosure Material		Enclosure Size (Inches)			# of Bars Ph and Size, Cu (Inches)	Ph-Ph Bus Spacing (Inches)	Insulating Supports			Optional Ground Bus, Cu (Inches)	Approx. Average Weight per Ft (Lb) ⑧	Listing	
				Standard	Optional	W	H	C			Standard	Optional ⑨	CSA			UL	
3	38	1200	9	Aluminum	—	40.25	21.50	11.00	(1) 0.25 x 4	10.50	Epoxy	—	—	0.25 x 3.00	61	Yes	No
	38	2000	10	Aluminum	—	40.25	21.50	11.00	(1) 0.38 x 4	10.50	Epoxy	—	—	0.25 x 3.00	89	Yes	No
	38	3000	11	Aluminum	—	40.25	23.50	12.00	(3) 0.5 x 4	10.50	Epoxy	—	—	0.25 x 3.00	121	No	No
3	38	1200	9	—	Steel	40.25	21.50	11.00	(1) 0.25 x 4	10.50	Epoxy	—	—	0.25 x 3.00	88	No	No
	38	2000	10	—	Steel	40.25	21.50	11.00	(1) 0.38 x 4	10.50	Epoxy	—	—	0.25 x 3.00	116	No	No

⑦ All bus bars for applications above 600V are fully insulated with fluidized epoxy coating for the rated maximum voltage.

⑧ Check with Eaton for availability.

⑨ Add 3 lb to the weights shown when using poly/porcelain or epoxy insulating supports in place of glass polyester.

Note: For dimensions in mm, multiply inches by 25.4.

Table 11.1-13. Non-Segregated Phase Bus Electrical Properties and Watt Loss Data

Wire Type	Rated Max. Voltage	Cont. Rated Current	Conductor (Copper)				Enclosure		Electrical Properties				
			#/ph	Thick	Width	Phase Arrangement	Material	Size	μohm/Ph/ft				Cap to Grd
	Inch	Inch		DC	60 Hz								
kV	Amperes						W x H (Inches)	R 20 °C	R	XL	Z = R+JXL	Cg	
3	0.635/5/15	1200	1	0.50	3.00	1-2-3	Aluminum	20.00 x 17.38	5.5	7.1	49.8	50.3	2.2
	0.635/5/15	2000	1	0.38	6.00	1-2-3	Aluminum	20.00 x 17.38	3.7	4.7	37.0	37.3	4.4
	0.635/5/15	3000	1	0.50	8.00	1-2-3	Aluminum	20.00 x 17.38	2.1	2.7	31.1	31.3	5.9
	0.635/5/15	3200	1	0.50	8.00	1-2-3	Aluminum	20.00 x 17.38	2.1	2.7	31.1	31.3	5.9
3	0.635/5/15	4000	2	0.50	6.00	1-1-2-2-3-3	Aluminum	35.75 x 17.38	1.4	1.8	35.6	35.6	5.9
	0.635/5/15	5000	2	0.50	8.00	1-1-2-2-3-3	Aluminum	35.75 x 17.38	1.0	1.3	32.9	32.9	7.8
	0.635/5/15	6000	4	0.50	5.00	1-2-3-1-2-3	Aluminum	35.75 x 26.82	0.7	1.1	6.3	6.39	14.9
3	0.635/5/15	1200	1	0.50	3.00	1-2-3	Steel	20.00 x 17.38	5.5	7.1	49.8	50.3	2.2
	0.635/5/15	2000	1	0.38	6.00	1-2-3	Steel	20.00 x 17.38	3.7	4.7	37.0	37.3	4.4
	0.635/5/15	3000	1	0.50	8.00	1-2-3	Steel	20.00 x 17.38	2.1	2.7	31.1	31.3	5.9
	0.635/5/15	3200	1	0.50	8.00	1-2-3	Steel	20.00 x 17.38	2.1	2.7	31.1	31.3	5.9
3	0.635/5/15	4000	2	0.50	8.00	1-1-2-2-3-3	Steel	35.75 x 17.38	1.0	1.3	32.9	32.9	7.8
	0.635/5/15	5000	2	0.50	8.00	1-2-3-1-2-3	Steel	35.75 x 17.38	1.0	1.3	14.6	14.6	7.4
	0.635/5/15	6000	4	0.50	5.00	1-2-3-1-2-3	Steel	35.75 x 26.82	0.7	1.1	6.3	6.39	14.9
4	0.635/5/15	1200	1	0.50	3.00	1-2-3-N	Aluminum	26.00 x 17.38	5.5	7.1	49.8	50.3	1.5
	0.635/5/15	2000	1	0.38	6.00	1-2-3-N	Aluminum	26.00 x 17.38	3.7	4.7	37.0	37.3	3.1
	0.635/5/15	3000	1	0.50	8.00	1-2-3-N	Aluminum	26.00 x 17.38	2.1	2.7	31.1	31.3	4.1
	0.635/5/15	3200	1	0.50	8.00	1-2-3-N	Aluminum	26.00 x 17.38	2.1	2.7	31.1	31.3	4.1
4	0.635	4000	2	0.50	6.00	1-1-2-2-3-3-N-N	Aluminum	35.75 x 17.38	1.4	1.8	35.6	35.6	4.9
	0.635	5000	2	0.50	8.00	1-1-2-2-3-3-N-N	Aluminum	35.75 x 17.38	1.0	1.8	32.9	32.9	9.4
	0.635	6000	4	0.50	5.00	1-2-3-N-1-2-3-N	Aluminum	35.75 x 26.82	0.7	1.1	6.3	6.39	14.9
4	0.635/5/15	1200	1	0.50	3.00	1-2-3-N	Steel	26.00 x 17.38	5.5	7.1	49.8	50.3	1.5
	0.635/5/15	2000	1	0.38	6.00	1-2-3-N	Steel	26.00 x 17.38	3.7	4.7	37.0	37.3	3.1
	0.635/5/15	3000	1	0.50	8.00	1-2-3-N	Steel	26.00 x 17.38	2.1	2.7	41.1	41.2	4.1
	0.635	3200	1	0.50	8.00	1-2-3-N	Steel	26.00 x 17.38	2.1	2.7	41.1	41.2	4.1
4	0.635	4000	2	0.50	8.00	1-1-2-2-3-3-N-N	Steel	35.75 x 17.38	1.0	1.8	32.9	32.9	9.4
	0.635	5000	2	0.50	8.00	1-1-2-2-3-3-N-N	Steel	35.75 x 17.38	1.0	1.8	32.9	32.9	9.4
	0.635	6000	4	0.50	5.00	1-2-3-N-1-2-3-N	Steel	35.75 x 26.82	0.7	1.1	6.3	6.39	14.9
3	27	1200	1	0.25	4.00	1-2-3	Aluminum	30.00 x 21.00	8.3	10.6	51.6	52.7	1.7
	27	2000	1	0.50	4.00	1-2-3	Aluminum	30.00 x 21.00	4.1	5.3	24.8	25.4	1.7
	27	1200	1	0.25	4.00	1-2-3	Steel	30.00 x 21.00	8.3	10.6	51.6	52.7	1.7
	27	2000	1	0.50	4.00	1-2-3	Steel	30.00 x 21.00	4.1	5.3	24.8	25.4	1.7
3	38	1200	1	0.25	4.00	1-2-3	Aluminum	40.25 x 21.50	8.3	10.6	61.3	62.3	2.0
	38	2000	2	0.38	4.00	1-2-3	Aluminum	40.25 x 21.50	4.1	5.3	59.0	59.2	2.0
	38	1200	1	0.25	4.00	1-2-3	Steel	40.25 x 21.50	8.3	10.6	61.3	62.3	2.0
	38	2000	2	0.38	4.00	1-2-3	Steel	40.25 x 21.50	4.1	5.3	59.0	59.2	2.0

Note: For dimensions in mm, multiply inches by 25.4.



Eaton
1000 Eaton Boulevard
Cleveland, OH 44122
United States
Eaton.com

© 2020 Eaton
All Rights Reserved
Printed in USA
Publication No. DG017001EN / Z24252
July 2020

Eaton is a registered trademark.

All other trademarks are property of their respective owners.