

Metal-enclosed medium-voltage power factor correction system



Contents

| Description | Page |
|--|------|
| Medium-voltage power factor correction | 1 |
| Product description | 1 |
| Application description | 2 |
| Advantages | 2 |
| Benefits | 2 |
| UniVAR XV (5 kV class) | 3 |
| Product description | 3 |
| Application description | 3 |
| Features, benefits, and functions | 3 |
| Technical data | 3 |
| Dimensions | 5 |
| AutoVAR MV (2.3–14.4 kV) | 6 |
| Product description | 6 |
| Features, benefits, and functions | 6 |
| Technical data | 10 |

Medium-voltage power factor correction

Product description

Eaton’s metal-enclosed medium-voltage capacitor systems and detuned filters are designed for indoor or outdoor applications in a wide variety of power systems requiring power factor correction and can increase system capacity. Designs are available with a host of options and accessories to fit the requirements and desired configurations of virtually any installation. Multi-stage metal-enclosed medium-voltage capacitor banks are designed for systems such as industrial, commercial, and utility power systems involving motors, feeder circuits, and transmission and distribution lines where power factor improvement is required.



Powering Business Worldwide

Application description

Utility customers

Metal-enclosed power factor correction systems are fully assembled, tested, and ready for installation. Very little field assembly is required. Installation and maintenance costs for metal-enclosed systems are low compared to pole and rack mounted capacitor banks. Metal-enclosed systems and detuned filters are less vulnerable to wildlife and airborne contaminants that can cause tracking and faults. In addition, metal-enclosed systems significantly reduce the risks and the associated liability involving arc-flash and untrained personnel. All live parts are contained in a grounded, key interlocked enclosure, and no internal hardware is accessible. Metal-enclosed systems are aesthetically pleasing due to their low profile, and can be painted to match the surrounding architecture. These are just some of the reasons more and more customers are using metal-enclosed capacitor and detuned filter systems.

Industrial customers

Many industrial power users can take advantage of the benefits associated with medium-voltage power factor correction. Medium-voltage solutions usually support the scale and scope of larger utility services. Medium-voltage applications can be found in the following types of industries: automotive, pulp and paper, plastics, petrochemical, and heavy manufacturing. Individual fixed capacitors provide power factor correction directly at the cause of the problem, such as large horsepower MV motors. Medium-voltage systems allow large facilities to correct power factor at or close to the point of common coupling (PCC), where the utility electrical system meets theirs. This allows correction for an entire facility, instead of having to correct at multiple locations. The NEMA® 3R design also allows the system to be placed outdoors, saving valuable manufacturing floor space. The savings can be significant in materials, installation costs, and floor space. In short, medium-voltage solutions can provide a cost-effective alternative to many local low-voltage power factor correction units.

Commercial customers

Many commercial customers are purchasing power from their utility at higher voltages today (2.3–15 kV), and can also take advantage of medium-voltage power factor correction systems. These solutions can meet the needs of large office complexes, hospitals, and universities, among others. The benefits of safety (key interlocking, no exposed live parts, etc.) and aesthetics (low profile, can be painted to match the environment) both meet the needs of these applications where there are large numbers of untrained personnel in proximity of electrical equipment.

Advantages

Eaton has over 75 years in the capacitor systems business. You can count on Eaton’s extensive power systems experience to provide a world-class solution to satisfy any power factor need. Quality and reliability are of paramount importance to not only the Eaton engineering team, but are also the backbone of all Eaton products and services. This commitment to quality means the customer can have a great deal of confidence with the medium-voltage capacitor or detuned filter solution from Eaton.

Benefits

Ease of installation

Eaton makes installation easy. All systems are completely assembled in the factory, with all equipment pre-wired and pre-tested for easy on-site installation. Only shipping splits must be connected in the field. Splice kits connect bus systems, and control wiring is easily connected at each enclosure. Current-limiting fuses, contactor assemblies, and the incoming switch assembly can be removed from the enclosure if needed. Line terminals are completely accessible from the front of the system. Bottom steel barrier at top of base channel is standard.

Personnel safety

A positive mechanical isolating switch with visible disconnect completely grounds and isolates the unit from the line connectors. All medium-voltage doors are mechanically interlocked with the disconnect switch. Key interlocks are provided standard on all enclosure doors, and can be coordinated with upstream disconnect devices. The low-voltage control section has a separate door-in-door design, and is segregated from the medium-voltage sections so that an operator can work in that section safely.

Ease of maintenance

All components are accessible through standard compartment doors, facilitating routine inspection or parts replacement. A viewing window is standard on all compartment doors, providing visual access to fuse and contactor status.

Flexibility

Systems are expandable. The customer can add stages in the future by connecting the phase bus in the field via splice kits. Structures can be bolted together in the field. Please specify requirements for future expansion when requesting a quote.



Safety and aesthetics are just two compelling reasons to use metal-enclosed PFC systems.



Insulated splice kits allow for simple interconnection in the field.

UniVAR XV (5 kV class)



UniVAR XV fixed medium-voltage PFC unit

Product description

Capacitors for medium-voltage, industrial applications:

- UniVAR capacitors are designed for power factor correction in applications where a fixed amount of capacitance (kvar) is required
- Available in voltage ratings of 2400 V, 4160 V, and 4800 V
- Fast economical payback
- Individual units or multiple assemblies can be designed
- Indoor dustproof/outdoor waterproof terminal box enclosures (NEMA 1, NEMA 12, NEMA 3R)
- Floor mounting



UniVAR XV with top and front covers removed

Application description

- Large motors
- Motor control centers
- Branch circuits
- Service entrances

Features, benefits, and functions

Standard features

Enclosure terminal box

Fourteen-gauge steel finished with durable baked-on powder coat finish. The wiring enclosure is gasketed to create a weatherproof, dustproof seal. Universal mounting flanges are provided for floor installation. The elimination of knockouts permits indoor/outdoor use. Unit meets NEMA 1, 3R, and 12 requirements. Enclosure is painted ANSI 61 gray.

Features

- Viewing window
- Top and side entry
- Removable top and front covers

Standard fusing

Fuses are rated 50,000 A symmetrical interrupting capacity. Ratings are 165% to 250% of rated current. Fuses have visual pop-up blown fuse indication standard.

Discharge resistors

These reduce the residual voltage to less than 50 V residual within five minutes of de-energization.

Grounding stud

- Standard

Power line terminals

- Large size for easy connection
- Plated copper one-hole termination pad

Operating temperature

- -40 °F to +115 °F (-40 °C to +46 °C)

Optional features

- CSA® testing and labels

Technical data

Table 1. UniVAR three-phase ratings

| Volts | Hz | kvar |
|-------|----|--------|
| 2400 | 60 | 25–825 |
| 4160 | 60 | 25–900 |
| 4800 | 60 | 25–900 |

Table 2. UniVAR XV

| kvar | 2400 V | 4160 V | 4800 V | Dimension (A) inches (mm) | Approximate weight lb (kg) | Figure number |
|-------------|---------------|---------------|---------------|--------------------------------------|---------------------------------------|----------------------|
| 25 | 25243MVF3 | 25413MVF3 | 25483MVF3 | 34.44 (875) | 70 (32) | 1 |
| 50 | 50243MVF3 | 50413MVF3 | 50483MVF3 | 34.44 (875) | 70 (32) | 1 |
| 75 | 75243MVF3 | 75413MVF3 | 75483MVF3 | 34.44 (875) | 70 (32) | 1 |
| 100 | 100243MVF3 | 100413MVF3 | 100483MVF3 | 36.19 (919) | 75 (34) | 1 |
| 125 | 125243MVF3 | 125413MVF3 | 125483MVF3 | 36.19 (919) | 83 (38) | 1 |
| 150 | 150243MVF3 | 150413MVF3 | 150483MVF3 | 36.19 (919) | 88 (40) | 1 |
| 175 | 175243MVF3 | 175413MVF3 | 175483MVF3 | 36.19 (919) | 93 (42) | 1 |
| 200 | 200243MVF3 | 200413MVF3 | 200483MVF3 | 36.19 (919) | 99 (45) | 1 |
| 225 | 225243MVF3 | 225413MVF3 | 225483MVF3 | 41.94 (1065) | 109 (49) | 1 |
| 250 | 250243MVF3 | 250413MVF3 | 250483MVF3 | 41.94 (1065) | 109 (49) | 1 |
| 275 | 275243MVF3 | 275413MVF3 | 275483MVF3 | 41.94 (1065) | 121 (55) | 1 |
| 300 | — | 300413MVF3 | 300483MVF3 | 41.94 (1065) | 121 (55) | 1 |
| 300 | 300243MVF3 | — | — | 36.19 (919) | 172 (78) | 2 |
| 325 | 325243MVF3 | 325413MVF3 | 325483MVF3 | 36.19 (919) | 177 (80) | 2 |
| 350 | 350243MVF3 | 350413MVF3 | 350483MVF3 | 36.19 (919) | 182 (83) | 2 |
| 375 | 375243MVF3 | 375413MVF3 | 375483MVF3 | 36.19 (919) | 188 (85) | 2 |
| 400 | 400243MVF3 | 400413MVF3 | 400483MVF3 | 36.19 (919) | 194 (88) | 2 |
| 425 | 425243MVF3 | 425413MVF3 | 425483MVF3 | 41.94 (1065) | 206 (93) | 2 |
| 450 | 450243MVF3 | 450413MVF3 | 450483MVF3 | 41.94 (1065) | 214 (97) | 2 |
| 475 | 475243MVF3 | 475413MVF3 | 475483MVF3 | 41.94 (1065) | 214 (97) | 2 |
| 500 | 500243MVF3 | 500413MVF3 | 500483MVF3 | 41.94 (1065) | 214 (97) | 2 |
| 525 | 525243MVF3 | 525413MVF3 | 525483MVF3 | 41.94 (1065) | 226 (103) | 2 |
| 550 | 550243MVF3 | 550413MVF3 | 550483MVF3 | 41.94 (1065) | 238 (108) | 2 |
| 575 | — | 575413MVF3 | 575483MVF3 | 41.94 (1065) | 238 (108) | 2 |
| 575 | 575243MVF3 | — | — | 36.19 (919) | 259 (118) | 3 |
| 600 | — | 600413MVF3 | 600483MVF3 | 41.94 (1065) | 238 (108) | 2 |
| 600 | 600243MVF3 | — | — | 36.19 (919) | 265 (121) | 3 |
| 625 | 625243MVF3 | 625413MVF3 | 625483MVF3 | 41.94 (1065) | 279 (127) | 3 |
| 650 | 650243MVF3 | 650413MVF3 | 650483MVF3 | 41.94 (1065) | 287 (131) | 3 |
| 675 | 675243MVF3 | 675413MVF3 | 675483MVF3 | 41.94 (1065) | 295 (134) | 3 |
| 700 | 700243MVF3 | 700413MVF3 | 700483MVF3 | 41.94 (1065) | 295 (134) | 3 |
| 725 | 725243MVF3 | 725413MVF3 | 725483MVF3 | 41.94 (1065) | 295 (134) | 3 |
| 750 | 750243MVF3 | 750413MVF3 | 750483MVF3 | 41.94 (1065) | 295 (134) | 3 |
| 775 | 775243MVF3 | 775413MVF3 | 775483MVF3 | 41.94 (1065) | 307 (140) | 3 |
| 800 | 800243MVF3 | 800413MVF3 | 800483MVF3 | 41.94 (1065) | 319 (145) | 3 |
| 825 | 825243MVF3 | 825413MVF3 | 825483MVF3 | 41.94 (1065) | 331 (151) | 3 |
| 850 | — | 850413MVF3 | 850483MVF3 | 41.94 (1065) | 331 (151) | 3 |
| 875 | — | 875413MVF3 | 875483MVF3 | 41.94 (1065) | 331 (151) | 3 |
| 900 | — | 900413MVF3 | 900483MVF3 | 41.94 (1065) | 331 (151) | 3 |

Note: Add suffix "C" for CSA label.

Dimensions

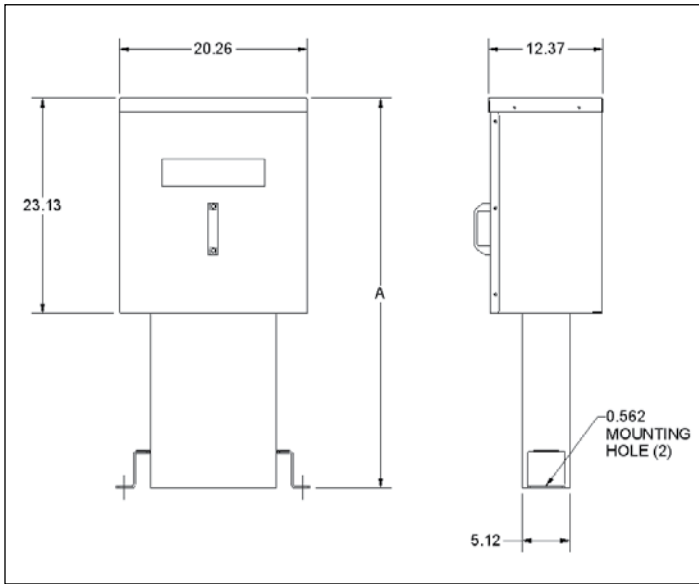

Figure 1. UniVAR XV outline drawing

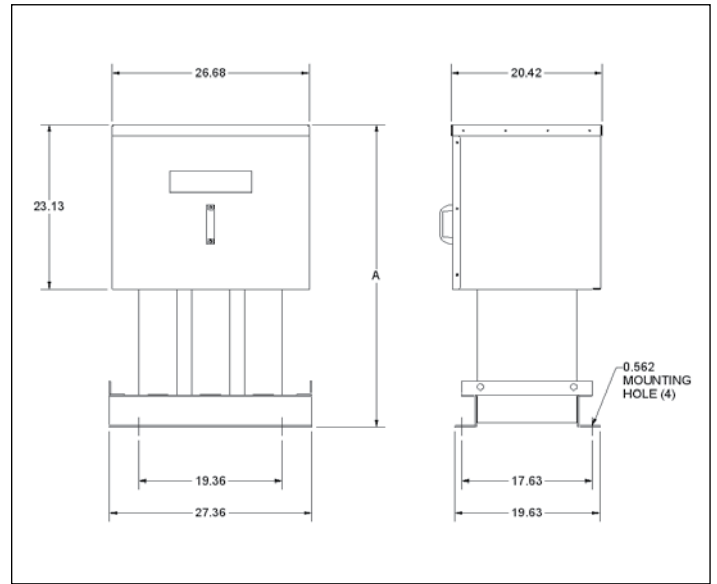

Figure 3. UniVAR XV outline drawing

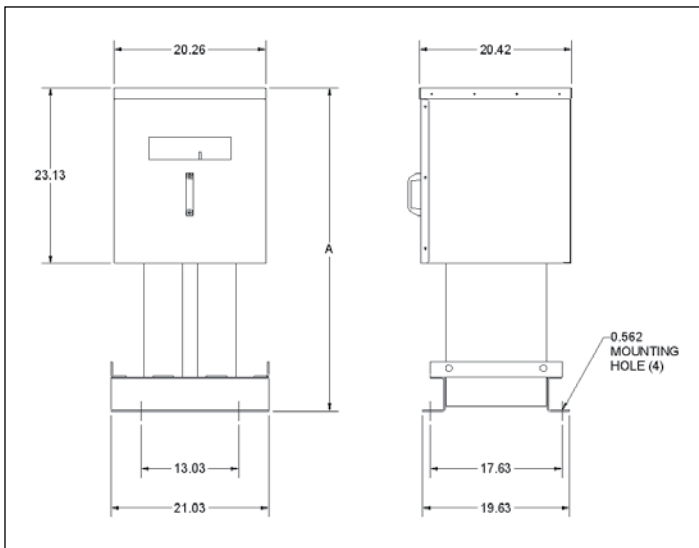
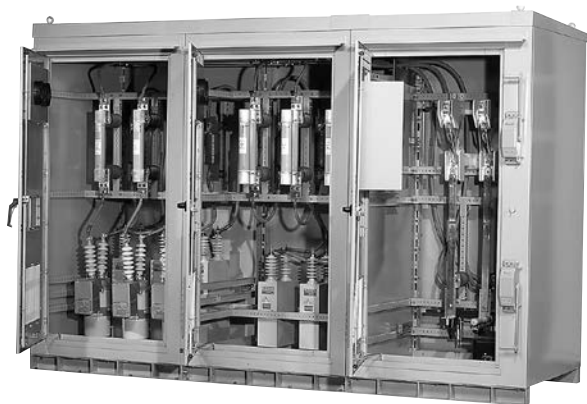

Figure 2. UniVAR XV outline drawing

AutoVAR MV (2.4–14.4 kV)



Medium-voltage metal-enclosed PFC system

Product description

AutoVAR medium-voltage automatic power factor capacitor systems are designed for power factor correction in applications where plant power factor can be constant or changing and a custom solution is required. These systems can be a fixed amount of capacitance with a disconnect, a number of switched capacitance stages, or a combination of both. The AutoVAR medium-voltage capacitor system can switch stages of capacitance in and out automatically based on information collected by the power factor controller on the door-in-door control panel.

Features, benefits, and functions

- Voltages from 2300 to 14,400 V
- Wide range of reactive power ratings available
- Unfiltered, detuned, or multi-tuned designs available in the following sizes:
 - 5 kV unfiltered
 - Banks up to 5500 kvar
 - Stages up to 1500 kvar
 - 5 kV filtered
 - Banks up to 4500 kvar
 - Stages up to 1500 kvar
 - 15 kV unfiltered
 - Banks up to 10,000 kvar
 - Stages up to 3500 kvar
 - 15 kV filtered
 - Banks up to 9500 kvar
 - Stages up to 2300 kvar

Note: Larger units can be evaluated and provided upon request.

- Externally fused capacitor units standard
- Blown fuse indication standard
- Integral main switch with NEMA two- or four-hole termination pad for incoming cables standard
- Factory tested and ready for interconnection
- Integral protection and control system standard
- Top or bottom cable entry
- Grounding switch

- 60 kV BIL up to 4.8 kV
- 95 kV BIL or 110 kV BIL from 7.2 kV to 14.4 kV
- Up to six switched capacitor stages
- Fixed, automatic, or remotely controlled stage operation
- Warning labels
- Replaceable air filters
- Adjustable blocking timers to prevent re-closing of a capacitor stage in less than 200 seconds
- Meets the following requirements:
 - ANSI
 - IEEE®
 - NEC®
 - NESC
 - CSA (when specified)
- Standard main incoming fuses are rated 50 kAIC to provide main bus protection, as well as backup protection for the capacitor systems
- 4.00-inch base channel is standard

Standard features

Enclosure

Free-standing, 11-gauge steel construction with three-point padlockable latching handles and stainless steel hinges. The enclosure is painted with a corrosion-resistant ANSI 61 light gray powder-coated paint as standard. Other colors are available as an option. NEMA 3R construction is standard.

Enclosure type is UL®/CSA approved. Enclosure design is modular, and future sections can be added on the left or the right.

See **Figure 4** for typical dimensions and elevations.

See **Figure 5** for a typical single-line drawing.



Medium-voltage PFC enclosure



Bottom plate incoming cutout provided standard

Main air disconnect switch

Integral disconnect switch, externally operated, mechanically chain driven with visible blades is available as per NEC requirements. Disconnect switch is mechanically interlocked with the ground switch, and Kirk key is interlocked with the customer's upstream device (if applicable). For safety, the incoming section is front-accessible only, and a barrier isolates live components from the user.



Incoming section

Ground switch

A ground switch is provided to ground the load-side terminals of the incoming switch (or MLO) for safety during maintenance. Optional controls are available to permit closing contactors after the grounding switch has been closed to ground capacitors immediately (rather than waiting 5 minutes for full discharge).

Vacuum switches and contactors rated for capacitor switching

On 2.4 kV to 4.8 kV multi-stage capacitor systems, each stage is controlled by low maintenance Eaton "SL" AMPGARD® three-pole vacuum contactors. On 6.6 kV to 14.4 kV multi-stage capacitor systems, each stage is controlled by low maintenance single-pole vacuum switches. Three-pole zero voltage control switches are available as an option.



15 kV switched capacitor stage enclosure

The type SL power contactors are self-supporting, compact, three-pole vacuum contactors, rated for capacitor switching. The SL contactor uses a solid-state control board, allowing the user maximum flexibility to change control voltages and dropout times in the field simply by adjusting DIP switch settings. The SL contactor is available in voltage ratings from 2.4 kV to 4.8 kV with current ratings of 200 A to 800 A (the highest rated capacitor switching contactor available), and the SL contactor has interruption ratings of 8500 A, allowing for better coordination with power fuses.

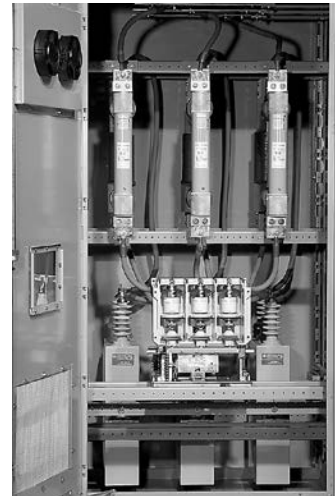

5 kV switched capacitor stage enclosure

Individual capacitor fusing

Each capacitor is externally fused with current-limiting fuses. Fuses are equipped with blown fuse indication. Fuses are rated for capacitor protection. All fuses are rated 50 kAIC.

Environmental controls

- Exhaust fans are provided for forced air ventilation of all enclosures as standard
- Thermostats, for control of fans and space heaters, are located in each compartment as standard to regulate internal environmental conditions
- Space heaters are provided to control moisture and humidity inside all enclosures

Capacitors

Low loss, double-bushing capacitors meet or exceed IEC 871, IEEE Std. 18, and CSA standards. Capacitor banks are available in delta, ungrounded wye, or ungrounded double wye. The dielectric fluid contains no polychlorinated biphenyls (PCBs). Capacitor units are equipped with internal discharge resistors that reduce the residual voltage to less than 50 volts within 5 minutes of de-energization.

Detuned filtering

Eaton’s medium-voltage harmonic filter systems are designed for industrial, utility, and commercial power systems to improve power factor and increase system capacity. These filters are designed to the unique specifications of each electrical distribution system. Medium-voltage capacitor banks can be configured with detuned anti-resonant harmonic filters, typically set to the 4.2nd harmonic. Capacitor banks detuned to the 4.2nd or 4.7th harmonic prevent parallel resonance conditions and reduce transients.

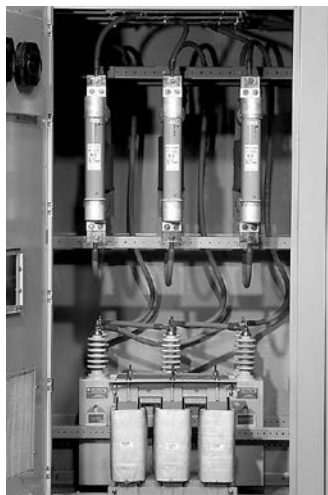

Detuned filter capacitor stage enclosure

Key interlock system

The key interlock system controls the sequential operation of the main switch (or circuit breaker) and the ground switch to permit safe entry into the capacitor system. All capacitor stage enclosures are also interlocked with the ground switch (if equipped). If applicable, the customer’s upstream disconnect device can be interlocked as well. See **Figure 5** for key interlock operation on a typical single-line drawing.

Blown fuse detection system

A visual pop-up blown fuse detection system is provided as standard.

Control power transformer

A standard fused control power transformer rated for 1.5 kVA is provided for protection, control, and operation of the capacitor or harmonic filter system.

Surge protective device (SPD)

A standard UL listed SPD unit is supplied for protection of all low-voltage controls in the system, increasing the reliability of the system.

Control panel

A door-in-door NEMA 3R swing-out control panel is provided on the main incoming structure as standard. This unit includes a viewing window so that all controls and information can be viewed without opening the panel. All low-voltage controls and logic are accessible from the front of the system, and are isolated from the medium-voltage section.

Standard items:

- PFC power factor controller
- Multifunction digital meter/relay
- LED lights for status, alarm, and trip indication
- Manual stage operation switches



Control panel

Microprocessor-based controller

Switched metal-enclosed capacitors and detuned filter systems come standard equipped with an automatic controller that switches each capacitor stage based upon power factor. The customer simply programs in the target power factor desired. The controller analyzes the present power factor, the size of each stage, and turns on and off stages to meet the customer’s programmed target. The power factor controller comes with the following alarms as standard: over/under compensation, no current input, step fault, step warning, target PF not reached, total voltage harmonic distortion, total current harmonic distortion, and over/undervoltage.

Up to six steps of capacitance can be designed into any system. Customers can exploit this feature when designing systems for future plant expansion.

Communication options

Communications of power factor data via RS-485. Modbus® is available as an option. Communicated information from the controllers:

- Voltage
- Current
- Target power factor
- Current power factor
- Active power
- Apparent power
- Reactive power
- Number of steps in the circuit
- All alarm status
- All counters
- Time and date

Communications of power factor data

Optional integrated Eaton Power Xpert® Gateway is available for Ethernet applications.

Inrush reactors

Series air core inrush reactors are provided as standard on all switched (non-filtered) capacitor systems for protection against transients from back-to-back switching. Reactors in filtered applications provide this same protection.

Bus

Standard main bus is continuous 1/4 x 2-inch silver-plated copper bus rated 500 A and is provided throughout the lineup for easy interconnection, field installation, and future expansion.

Ground bus is continuous 1/4 x 1-inch silver-plated copper and is provided throughout the lineup for easy interconnection, field installation, and future expansion. Ground studs are available in all structures for customer connection.

Additional standard controls and features

- Three-phase current monitoring of capacitor bank
- Unbalance alarm and unit shutdown on all wye-connected systems
- Each section has thermostatically controlled space heaters
- Unit alarm and isolated fail-safe contacts for customer use on all systems. Controls allow sufficient time (5 minutes) to allow the capacitors to discharge before re-energization can occur
- Temperature alarms on all detuned filter units
- Manual stage controls (H-O-A selector switches)

Optional features

Detuned filter reactors

Iron core reactors provide the necessary reactance to detune the capacitor system to a desired frequency. Standard filters can be detuned to 4.2, 4.4, 4.6, or 4.7, with other tuning frequencies available if needed. Iron core reactors are 100% copper windings, 115 °C rise with 220 °C insulation VPI varnish.



Reactors for detuned filter

Lightning arresters

Standard distribution heavy-duty class, optional intermediate or station class lightning arresters protect the capacitor system from lightning and switching transients.

15 kV capacitor vacuum switch

15 kV capacitor vacuum switch is available in vacuum contactor in oil dielectric or vacuum contactor in solid dielectric. Vacuum switches are certified to ANSI C37.66 standard.

ZVC (Zero Voltage Close) capacitor vacuum switch with solid dielectric

Virtually eliminates switching transients by closing when the voltage across the switch is zero. ZVC switches conform to ANSI C37.66 standard.

Multifunction digital meter/relay

Multifunction meter/relay with current and voltage monitoring and various alarm/trip set points.

Alarm strobe

Strobe light can be provided for visual indication of faults and alarms.

Unbalance protection

Neutral PT or CT-based unbalance protection for wye ungrounded capacitor configuration.

Time delayed enclosure entry interlock

Electrically controlled solenoid time delay to allow adjustable time delay between opening of main switch and entry into capacitor section.

Heavy-duty capacitor units

Capacitor units suited to the rigors of industrial power systems for power factor, harmonic filter, and excessive switching applications. Heavy-duty capacitor units have 125% continuous rms overvoltage capability, 15,000 A fault handling capability, 100 kA transient current withstand capability, 131 °F (55 °C) ambient temperature operation, and 135% peak overvoltage capability.

CSA labels for assembly

Factory CSA label for assembly is available for selected designs.

Communications gateway

Integrated Eaton Power Xpert Gateway allows remote monitoring of the Type CM controller via Ethernet.

Quick ship standard designs

Standard pre-engineered designs are available in the most commonly requested configurations. These units have shorter manufacturing lead times than custom designs.

For more information on standard medium-voltage units, please contact Eaton's Technical Resource Center (TRC) power factor application engineers at pfc@eaton.com.

Technical data

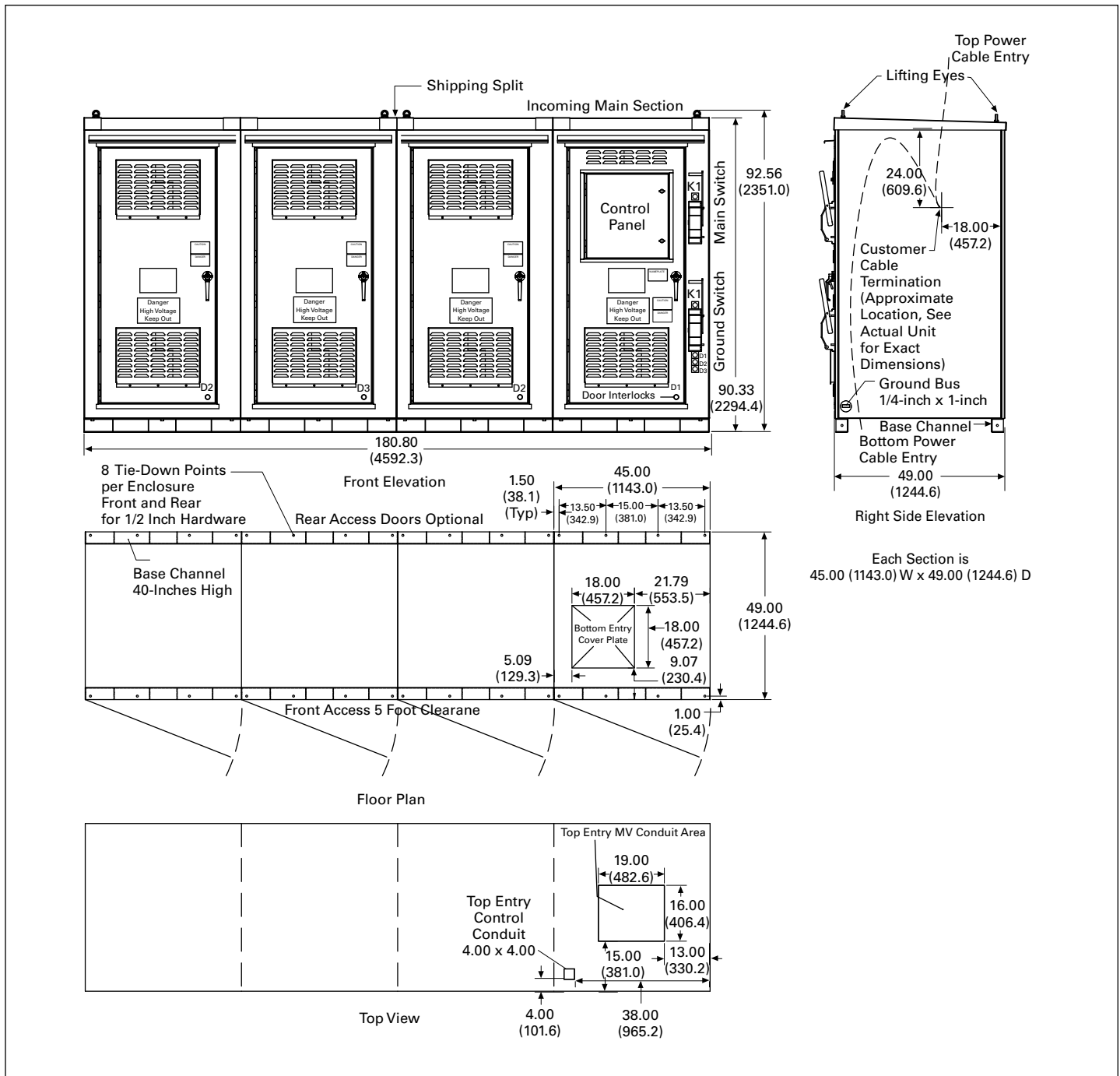

Figure 4. Typical engineered metal-enclosed power factor correction system dimensional data in inches (mm)

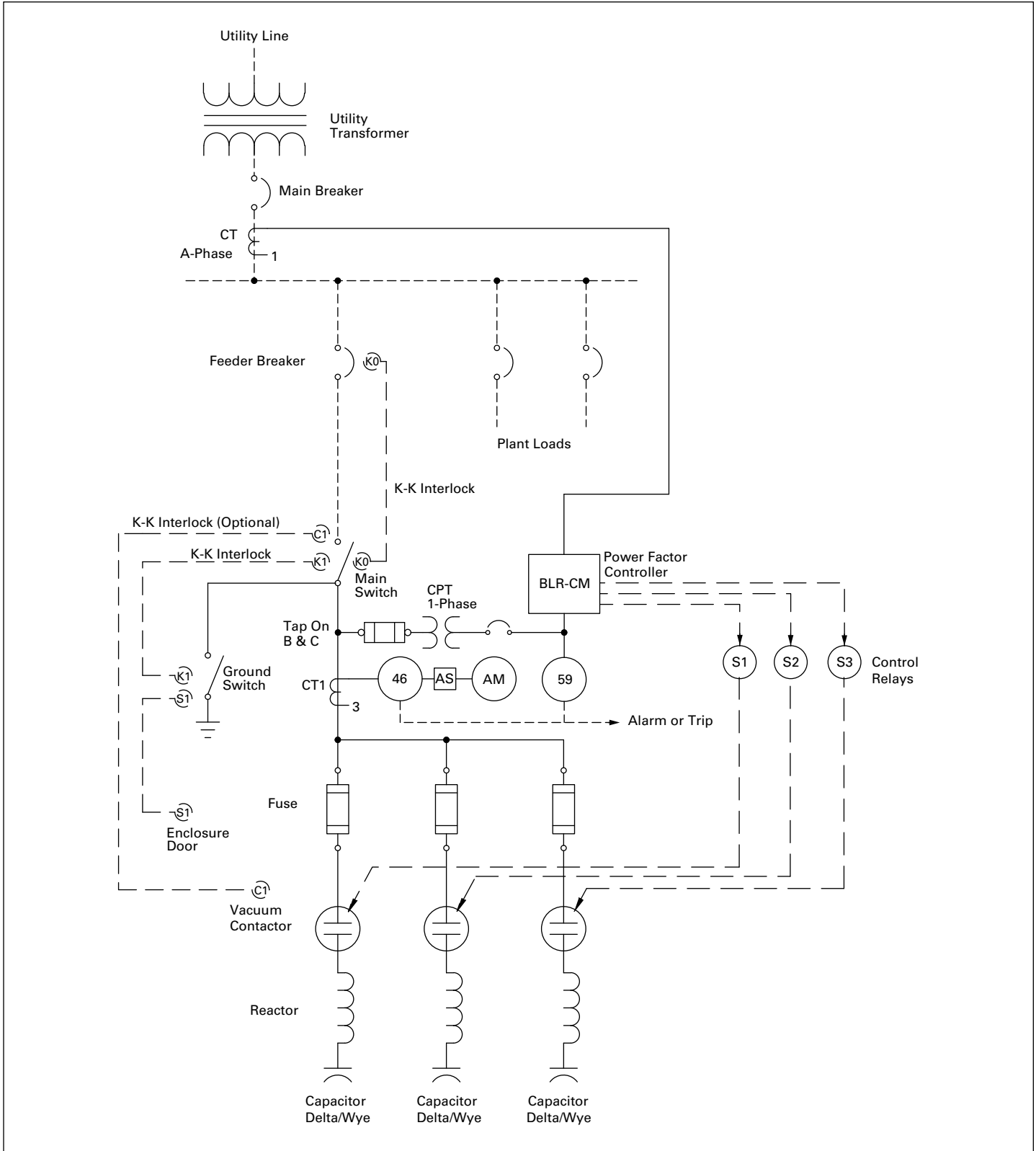

Figure 5. Typical medium-voltage automatic power factor correction single-line drawing

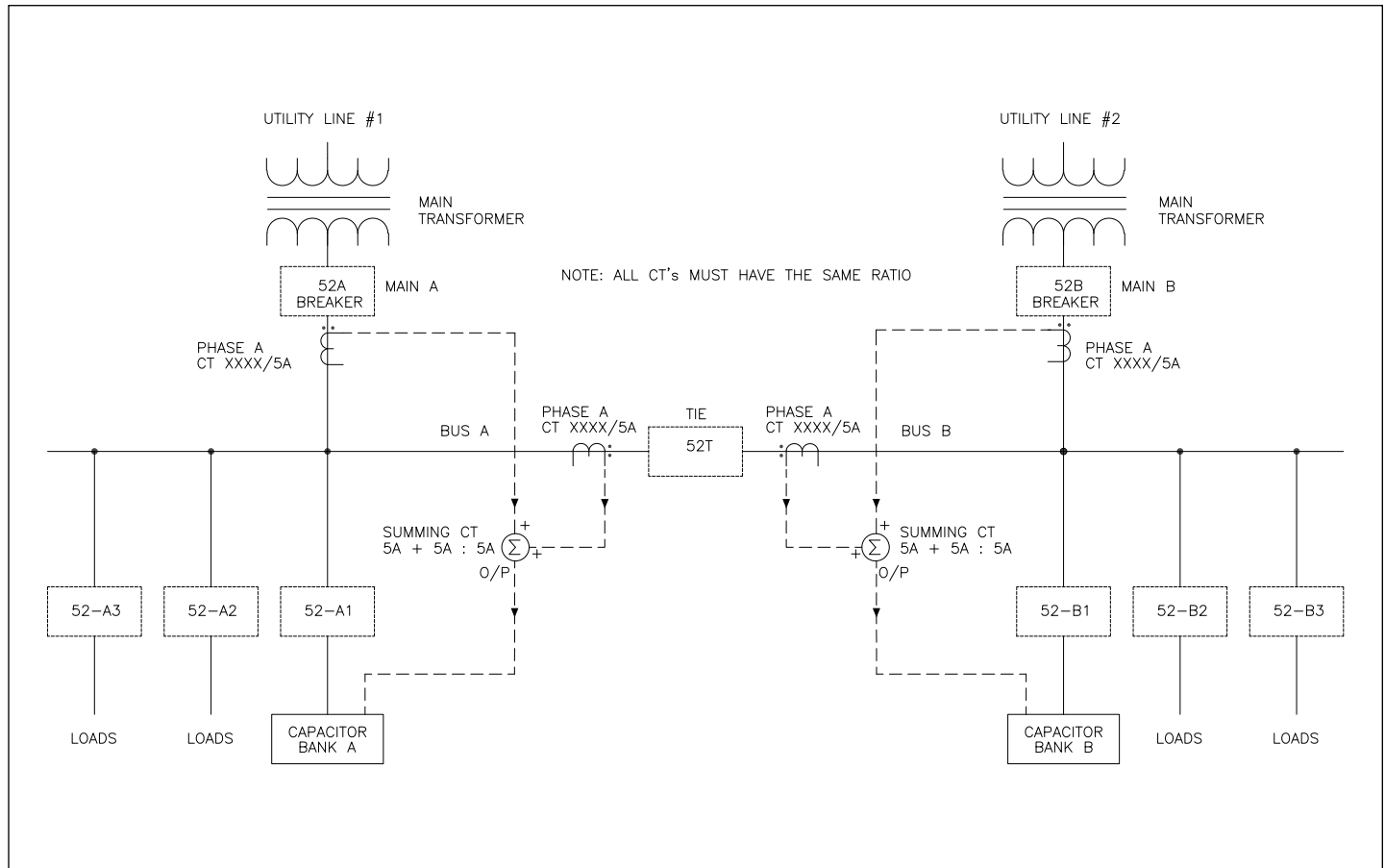

Figure 6. Typical automatic capacitor banks medium-voltage main-tie-main

For product support, please contact Eaton's power factor application engineers at Eaton.com/pfc

Eaton
1000 Eaton Boulevard
Cleveland, OH 44122
United States
Eaton.com

© 2021 Eaton
All Rights Reserved
Printed in USA
Publication No. TD02607011E / Z25143
June 2021