

# ULUSOY DRY TYPE TRANSFORMER

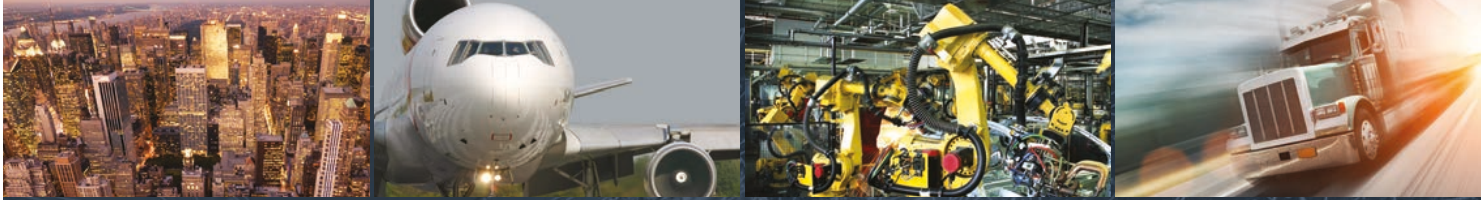

*Powering Business Worldwide*



# Energizing a world that demands more.

## We deliver:

- **Electrical solutions** that use less energy, improve power reliability and make the places we live and work safer and more comfortable
- **Hydraulic and electrical solutions** that enable machines to deliver more productivity without wasting power
- **Aerospace solutions** that make aircraft lighter, safer and less costly to operate, and help airports operate more efficiently
- **Vehicle drivetrain and powertrain solutions** that deliver more power to cars, trucks and buses, while reducing fuel consumption and emissions

Discover today's Eaton.

## Powering business worldwide

As a global power management company, we help customers worldwide manage the power needed for buildings, aircraft, trucks, cars, machinery and businesses.

Eaton's innovative technologies help customers manage electrical, hydraulic and mechanical power more reliably, efficiently, safely and sustainably.

We provide integrated solutions that help make energy, in all its forms, more practical and accessible.

With 2019 sales \$21.4 billion, Eaton has approximately 95,000 employees around the world and sells products in more than 175 countries.

[Eaton.com](https://www.eaton.com)

**EATON**

*Powering Business Worldwide*

## TABLE OF CONTENTS

<b>Introduction .....</b>	<b>2</b>
<b>Standards .....</b>	<b>2</b>
<b>Advantages of dry type transformers .....</b>	<b>3</b>
<b>Dry type transformer areas of use .....</b>	<b>3</b>
<b>Products .....</b>	<b>3</b>
<b>Transformer manufacturing .....</b>	<b>4</b>
<b>Parts .....</b>	<b>5</b>
<b>Accessories .....</b>	<b>6</b>
<b>Dry type transformers working under demanding operating conditions .....</b>	<b>7</b>
<b>Dry type transformer manufacturing technology .....</b>	<b>8</b>
<b>Technical information .....</b>	<b>10</b>
<b>Tests .....</b>	<b>12</b>
<b>Packaging .....</b>	<b>13</b>

# Introduction

Eaton Ankara manufactures high-quality, high-performance dry type distribution transformers for various applications. Compliant with specific and international standards, these transformers can be used above sea level and in marine environments. They can also be used under demanding operating conditions. It provides general environmental safety with non-flammable liquids, self-extinguishing material, non-toxic gas emissions, low noise levels and low electromagnetic emissions.

Dry type distribution transformers are moisture-proof, making them suitable for operation in humid environments or where pollution is high. These transformers work in environments with over 95% humidity as well as at temperatures down to -25°C.

## Standards

Dry type transformers are manufactured according to the following national and international standards:

- TS EN
- IEC
- IEEE
- CENELEC EN
- DIN EN 50588-1

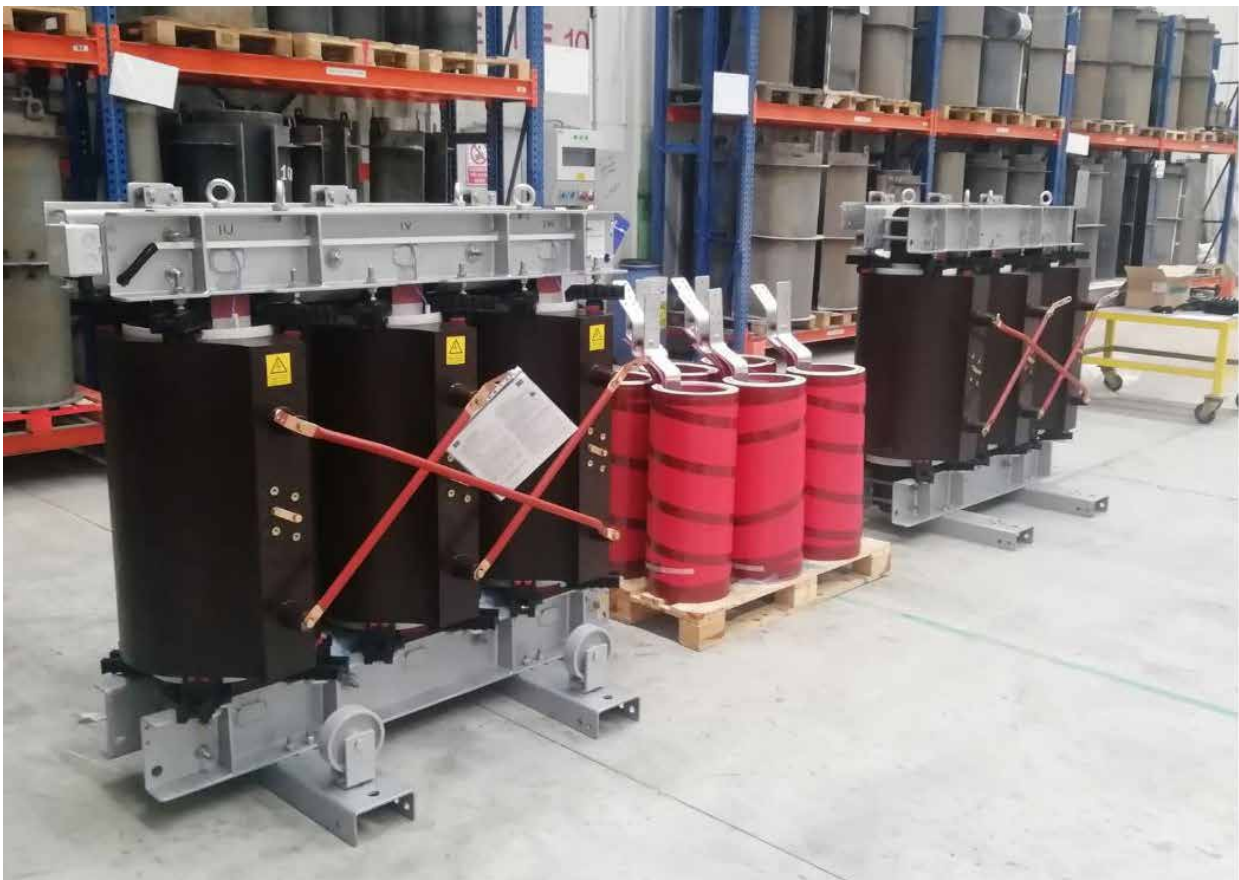

# Advantages of dry type transformers

## Health and safety

- Non-flammable and self-extinguishing.
- Resistant to moisture.
- Does not cause environmental pollution.
- Environmentally friendly insulation materials without halogen or nitrogen.

## Functionality and cost

- Requires minimal maintenance (once a year).
- No risk of leaks.
- On-site maintenance and repair service.
- Can be installed very close to highly populated areas.
- Low operating and installation costs.
- Special safety measures not required thanks to self-extinguishing materials.

## Life and durability

- Cooling can increase the nominal power of the transformer by 40%.
- Longer service life due to low partial discharge.
- High insulation levels provide resistance to short circuiting and lightning strikes.
- Performs better than oil type transformers in short-term overloads.
- High mechanical resistance against short circuit.

# Dry type transformer areas of use

Dry type transformers can be used in a wide range of settings. They can be used in distribution systems, cogeneration systems, rectifier and traction applications.

- Internal and external transformer centers
- Industry and oil refineries
- Subways
- Oil platforms
- Energy production facilities
- Schools
- Hospitals
- Airports
- Shopping centers
- Wind farms
- Solar farms

# Products

We produce standard and customized transformers as required by the market.

# Transformer manufacturing

Rated frequency	Hz	As per request. (50 Hz–60 Hz...)
Rated powers	kVA	Up to 3150 kVA (Transformer requests between 3150 kVA and 5000 kVA are evaluated on a project-by-project basis.)
Rated voltages		
Medium voltage winding	kV	Up to 36 kV
Low voltage winding	V	As per request
Environmental class		E0 / E1 / E2
Climate class		C1 / C2
Fire behavior class		F0 / F1

## Climate class

**C1:** Dry type transformers cannot be energized below  $-50\text{ }^{\circ}\text{C}$ . They can only be transported and stored in environments down to  $-25\text{ }^{\circ}\text{C}$ .

**C2:** Dry type transformers can be energized, transported and stored in environments down to  $-25\text{ }^{\circ}\text{C}$ .

## Environmental class

**E0:** No condensation on the transformer, negligible pollution, installation in a clean and dry room.

**E1:** Low condensation and low pollution.

**E2:** Transformer is subject to constant condensation, high pollution or both.

## Fire behavior class

**F0:** Likelihood of fire is negligible and no measures are taken to limit flammability.

**F1:** Transformer is at potential risk of fire and flammability must be reduced. Fire on the transformer should go out within a specified time frame.

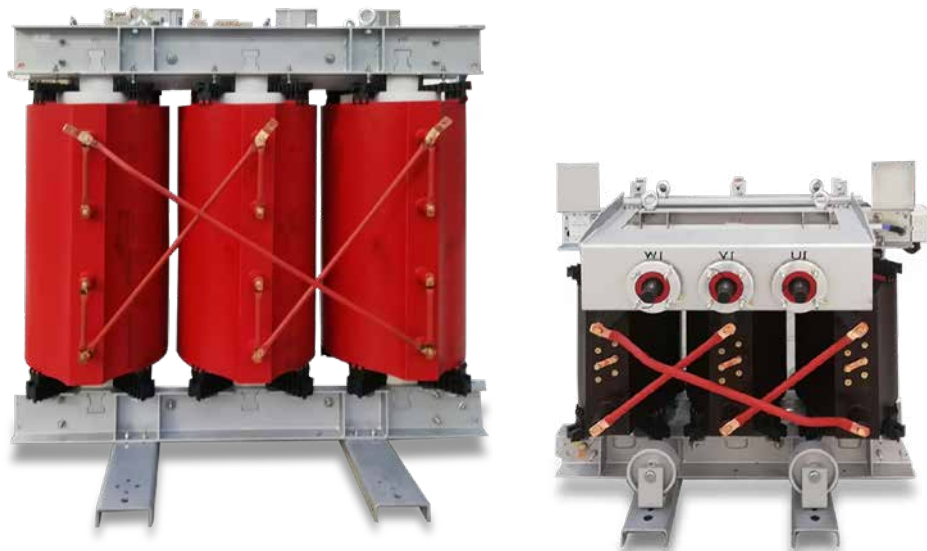

# Parts

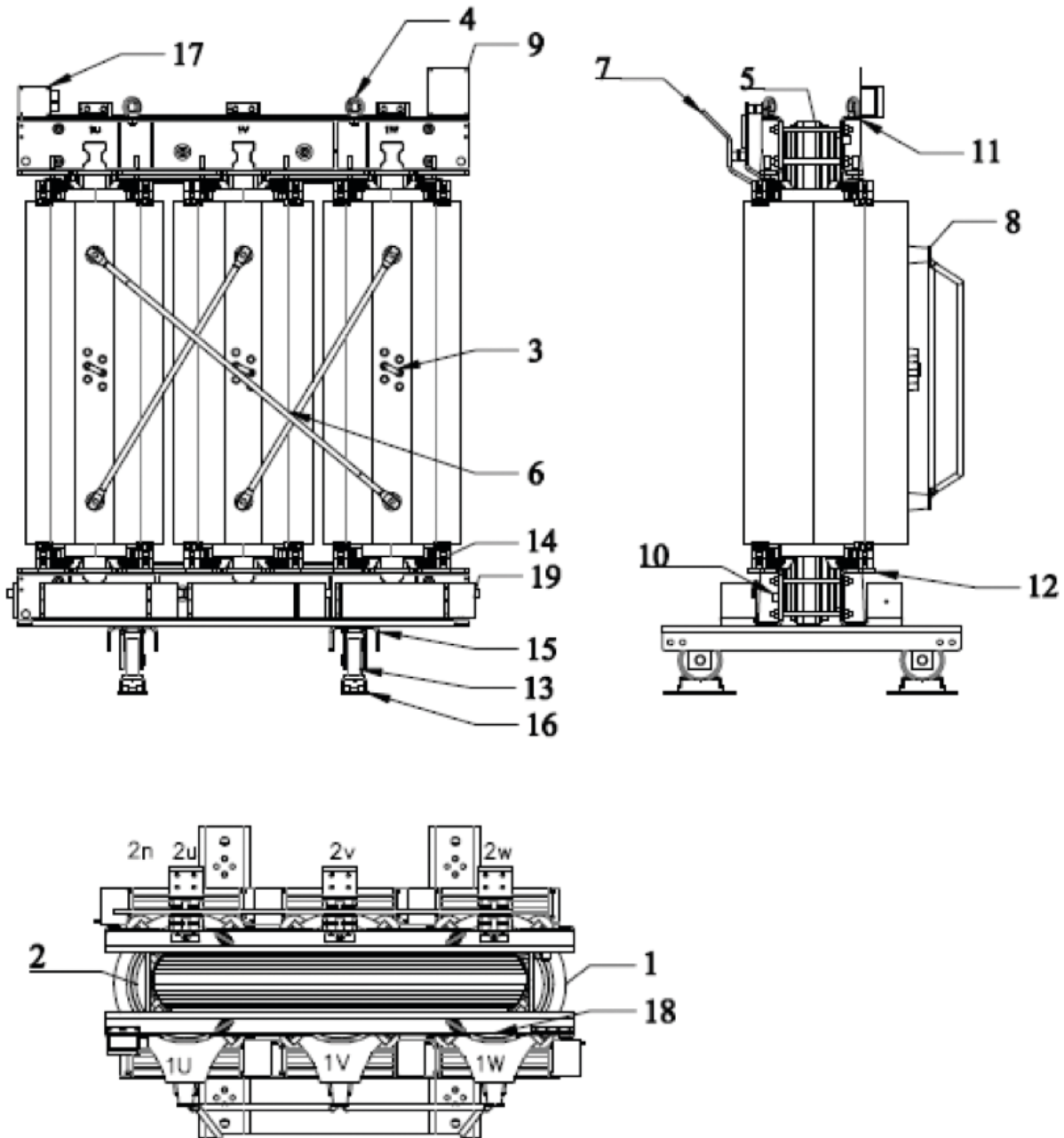

- |                                  |                        |
|----------------------------------|------------------------|
| 1. High voltage winding          | 11. Upper yoke bar     |
| 2. Low voltage winding           | 12. Lower yoke bar     |
| 3. Tap changing terminal         | 13. Wheel              |
| 4. Lifting rings                 | 14. Clamping wedges    |
| 5. Core                          | 15. Carrier            |
| 6. Triangle connection conductor | 16. Anti-vibration pad |
| 7. LV terminal                   | 17. Terminal box       |
| 8. HV terminal                   | 18. PT100              |
| 9. Warning plate                 | 19. Fan                |
| 10. Earthing terminal            |                        |

# Accessories

## Standard accessories

- Two-way adjustable wheels
- Lifting rings
- Terminal for earthing connection
- Temperature control relay
- PT100 thermal sensor and relay

## Optional accessories

- PTC thermistor (can be used instead of PT100)
- Cooling fans (can temporarily increase transformer power)
- Fan control relay (trip to keep temperature at the set level)
- Socket connection for high voltage connections
- Protection cells
- High voltage surge arresters
- Anti-vibration pads

## Wheels

Wheels in various diameters, selected to bear the transformer weight, are shipped with the transformer as per customer request.



## Anti-vibration pads

Placed on the base of the transformer wheels. These prevent vibration while the transformer is in operation.



## PT100 sensors

One is used in each phase for temperature control inside transformer LV windings. Can be used in the core upon customer request.



## Cooling fans

Six cooling fans are placed under the coils to keep the coils cool and temporarily increase the transformer's power by 40%.





### Temperature control relay

The temperature control system is designed to measure and control overheating, resulting from high ambient temperatures or transformer winding overload. For this purpose, PT100 or PTC temperature sensors are installed in low voltage windings with the highest temperature. In this system, alarm and trip signals are received according to the temperatures. The device connected to these sensors will sound an alarm and activate the breaker. In addition, if the transformer has a fan cooling system, this device also enables the fans to be turned on and off automatically.



# Dry Type Transformers Working under demanding operating conditions

## 1. Temperature control system (standard)

Measures and controls both high ambient temperature that may occur in the transformer windings or overheating caused by overloads. For this, PT100 or PTC temperature sensors are placed in the low voltage windings where the temperature is highest. In this system, alarm and trip signals are received according to the set temperatures. The device connected to these sensors will sound an alarm and activate the breaker. Also, if the transformer has a fan cooling system, the fans are automatically activated and deactivated by this device.

## 2. Cooling system (optional)

Specially designed cooling fans are used to increase the nominal power of dry type transformers by 40%. The fans automatically turn on and off with the help of heat sensors in the low voltage coils.

## 3. Anti-vibration pads (optional)

Anti-vibration pads reduce and isolate vibrations occurring in the transformer in applications relating to buildings, shopping malls, etc.

## 4. Protective enclosure (optional)

Dry type transformers are manufactured as standard without a protective enclosure (IP00). As per customer request and depending where the transformer will be placed, to protect against solid objects, water and dust

- IP 20 Internal
- IP 23 Internal and External
- IP 33 Internal and External transformer enclosures can be manufactured according to IEC 60529 standards.

Transformer protective enclosures in superior protection classes can also be custom designed (air-conditioned and heated).

# Dry type transformer manufacturing technology

## Primary winding

High voltage coils are manufactured using copper and aluminum flat, round or band conductors covered with F class (H class optional) glass fiber, as per customer request. In order to produce a homogeneous structure, voltage windings are poured under vacuum using resin. They are hardened in special drying ovens to high production standards to prevent cracking. As a result, dry type transformers have a long operational life with a very low partial discharge value.

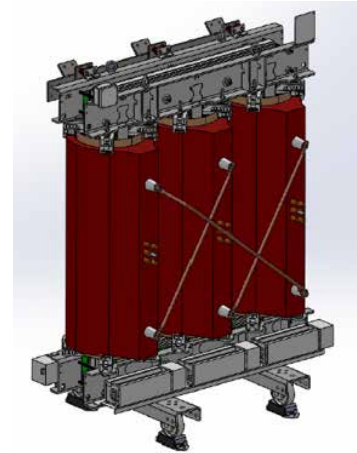

## Secondary winding

Belt (foil) winding conductors are used in low voltage windings because of their technical advantages. Copper or aluminum bands are used in the windings, as per customer request. Axial short circuit forces are reduced with the band winding technology. F class (H class optional) insulation material is saturated in the resin between the posts to control radial short circuit forces. Coils are hardened after the winding process, providing resistance and dielectric properties under the most demanding industrial atmospheric conditions.



## Core

Core sheet metal consist of low-loss, cold-rolled sheets with extruded cores. The core is cut and aligned with the step-lap cutting method. This method keeps transformer idling losses and noise levels to a minimum. Cores are painted with paint that is resistant to high temperatures, vibration and rust.



## Assembly

In dry type transformers, compression bars and compression wedges are used together at the top and bottom to compress the coils. These hold the cores and coils together. Coils are mounted with glass fiber reinforced supports to protect against short circuit forces and vibration. The wheels are designed to allow the transformer to move forward, backward, right and left. All steel parts used in transformer assembly are painted to prevent corrosion. The painting method is selected in accordance with the atmospheric conditions under which the transformer will operate.

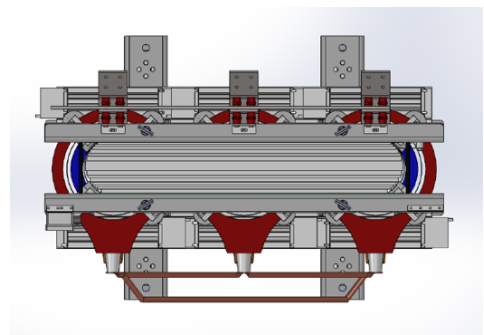

## Casting

High-quality epoxy resin components are used in the vacuum casting of HV coils in dry type transformers. Quartz sand is used as filling material. F or H thermal class epoxy resin and insulation materials are used in coils as per customer request.



# Technical information

## Dry type transformers produced according to ecodesign EU No. 548/2014 (Tier 1)

Voltage (kV)	Power (kVA)	Idling loss (W)	Load loss (W)	Short circuit (%)	Noise level (dB)	Length A (mm)	Width B (mm)	Height C (mm)	D (mm)	E (mm)	F (mm)	Total weight (kg)
7.2 - 12	250	520	3800	6	59	1260	750	1260	520	125	40	1090
	400	750	5500	6	61	1370	950	1360	670	160	50	1370
	630	1100	7600	6	63	1440	950	1540	670	160	50	1790
	800	1300	8000	6	64	1530	1100	1620	670	160	50	2220
	1000	1550	9000	6	65	1610	1100	1640	820	160	50	2550
	1250	1800	11000	6	67	1650	1100	1740	820	160	50	2950
	1600	2200	13000	6	68	1760	1100	1850	820	160	50	3560
	2000	2600	16000	6	72	1820	1200	2190	1070	200	70	4360
	2500	3100	19000	6	73	1930	1200	2300	1070	200	70	5230
	3150	3800	22000	6	76	2030	1200	2280	1070	200	70	5770

Voltage (kV)	Power (kVA)	Idling loss (W)	Load loss (W)	Short circuit (%)	Noise level (dB)	Length A (mm)	Width B (mm)	Height C (mm)	D (mm)	E (mm)	F (mm)	Total weight (kg)
17.5 - 24	250	520	3800	6	59	1460	750	1380	520	125	40	1470
	400	750	5500	6	61	1440	950	1640	670	160	50	1730
	630	1100	7600	6	63	1520	950	1640	670	160	50	2050
	800	1300	8000	6	64	1590	1100	1800	670	160	50	2620
	1000	1550	9000	6	65	1740	1100	1770	820	160	50	2980
	1250	1800	11000	6	67	1770	1100	1860	820	160	50	3440
	1600	2200	13000	6	68	1800	1100	2070	820	160	50	3950
	2000	2600	16000	6	72	1860	1200	2200	1070	200	70	4520
	2500	3100	19000	6	73	2020	1200	2220	1070	200	70	5310
	3150	3800	22000	6	76	2100	1200	2320	1070	200	70	6100

Voltage (kV)	Power (kVA)	Idling loss (W)	Load loss (W)	Short circuit (%)	Noise level (dB)	Length A (mm)	Width B (mm)	Height C (mm)	D (mm)	E (mm)	F (mm)	Total weight (kg)
36	250	598	4180	6	59	1550	750	1800	520	125	40	1960
	400	825	6050	6	61	1610	950	1840	670	160	50	2280
	630	1265	8360	6	63	1640	950	1970	670	160	50	2550
	800	1495	8800	6	64	1720	1100	2010	670	160	50	3070
	1000	1782	9900	6	65	1770	1100	2060	820	160	50	3440
	1250	2070	12100	6	67	1850	1100	2120	820	160	50	3940
	1600	2530	14300	6	68	1900	1100	2270	820	160	50	4500
	2000	2990	17600	6	72	2000	1200	2380	1070	200	70	5290
	2500	3565	20900	6	73	2090	1200	2520	1070	200	70	6230
	3150	4370	24200	6	76	2260	1200	2530	1070	200	70	7610

Dimensions and weights are approximate. May vary by order.

## Dry type transformers produced according to BS EN 50541-1: 2011 specification

Voltage (kV)	Power (kVA)	Idling loss (W)	Load loss (W)	Short circuit (%)	Noise level (dB)	Length A (mm)	Width B (mm)	Height C (mm)	D (mm)	E (mm)	F (mm)	Total weight (kg)
7.2 - 12	250	820	3500	6	65	1280	750	1160	520	125	40	990
	400	1150	4900	6	68	1380	950	1310	670	160	50	1330
	630	1500	7300	6	70	1440	950	1450	670	160	50	1720
	800	1800	9000	6	71	1530	1100	1550	670	160	50	2120
	1000	2100	10000	6	73	1600	1100	1620	820	160	50	2470
	1250	2500	12000	6	75	1650	1100	1700	820	160	50	2770
	1600	2800	14500	6	76	1760	1100	1790	820	160	50	3380
	2000	3600	18000	6	78	1810	1200	2060	1070	200	70	4010
	2500	4300	21000	6	81	1870	1200	2230	1070	200	70	4690
	3150	5300	26000	6	83	2010	1200	2350	1070	200	70	5630

Voltage (kV)	Power (kVA)	Idling loss (W)	Load loss (W)	Short circuit (%)	Noise level (dB)	Length A (mm)	Width B (mm)	Height C (mm)	D (mm)	E (mm)	F (mm)	Total weight (kg)
17.5 - 24	250	880	3800	6	65	1360	750	1280	520	125	40	1110
	400	1200	5500	6	68	1480	950	1380	670	160	50	1460
	630	1650	7600	6	70	1630	950	1470	670	160	50	1990
	800	2000	9400	6	72	1600	1100	1640	670	160	50	2240
	1000	2300	11000	6	73	1680	1100	1670	820	160	50	2590
	1250	2800	13000	6	75	1750	1100	1790	820	160	50	3110
	1600	3100	16000	6	76	1820	1100	1950	820	160	50	3620
	2000	4000	18000	6	78	1910	1200	2060	1070	200	70	4270
	2500	5000	23000	6	81	2040	1200	2110	1070	200	70	5090
	3150	6000	28000	6	83	2130	1200	2310	1070	200	70	6190

Voltage (kV)	Power (kVA)	Idling loss (W)	Load loss (W)	Short circuit (%)	Noise level (dB)	Length A (mm)	Width B (mm)	Height C (mm)	D (mm)	E (mm)	F (mm)	Total weight (kg)
36	250	1280	4000	6	67	1510	750	1470	520	125	40	1370
	400	1650	5700	6	69	1560	950	1660	670	160	50	1760
	630	2200	8000	6	71	1660	950	1790	670	160	50	2330
	800	2700	9600	6	72	1730	1100	1910	670	160	50	2730
	1000	3100	11500	6	73	1770	1100	2030	820	160	50	3120
	1250	3600	14000	6	75	1810	1100	2120	820	160	50	3620
	1600	4200	17000	6	76	1870	1100	2270	820	160	50	4280
	2000	5000	21000	6	78	1980	1200	2380	1070	200	70	5090
	2500	5800	25000	6	81	2080	1200	2470	1070	200	70	6010
	3150	6700	30000	6	83	2240	1200	2480	1070	200	70	7230

Dimensions and weights are approximate. May vary by order.

# Tests

Tests determined by national and international standards are performed in the factory test laboratory. In order to carry out these tests, the laboratory is equipped with the most sensitive measurement devices of the highest quality.

The routine, type and special tests listed below are performed in our laboratory to IEC 60076-1 and IEC 60076-11 standards.

Accreditation is carried out in our test laboratory to ensure international validity.

## Routine tests

- Measuring winding resistances
- Measuring voltage-to-turn ratio and checking voltage vector phase shift
- Measurement of short circuit impedance and loss under load
- Measuring idling losses and currents
- Dielectric routine tests
  - Applied voltage test
  - Induced voltage test
- Partial discharge measurement (routine test for dry type transformers)

## Special tests

- Determination of windings-to-earth capacitances and capacitances between windings; loss factor measurement (loss angle) ( $\tan$ ) of the insulation system capacitances.
- Measuring zero component impedance
- Measuring harmonics of idle current
- Routine testing of winding and winding insulation resistance (routine test according to TEDAŞ MYD specifications).

## Type tests

- Temperature increase test
- Lightning impulse test
- Measuring noise levels
- Short circuit mechanical strength test (KEMA, CESI, ICMET, BÜSTYAL)

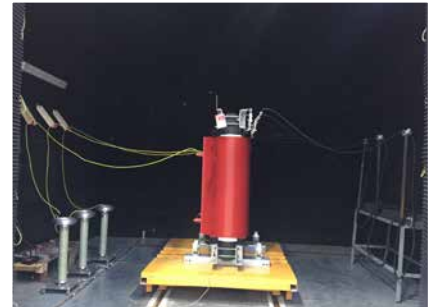

# Packaging

Transformers to be shipped are wrapped with stretch film after all accessories are added, as shown in the picture below. Products must be shipped in covered vehicles. Transformers should not be exposed to poor weather conditions.

Different packaging can be provided as per customer request.



**Ulusoy Elektrik Imalat Taahhüt ve Ticaret A.S.**

Anadolu OSB, Malıkoy Mah. Dumlupınar Cad.

N: 8 06909 Temelli—Ankara/TÜRKİYE

Tel: +90 312 502 06 63

ulusoy.info@eaton.com

www.eaton.com

© 2020 Eaton  
All rights reserved.

Eaton is a registered trademark.

Follow us on  
social media.

